



# Introduction

## 1.1.1 The County Council's vision statements

The Council Plan 2017 - 2021 '*Your Nottinghamshire, Your Future*' is focused around four vision statements. These are to make Nottinghamshire; '*a great place to bring up your family*', '*a great place to fulfil your ambition*', '*a great place to enjoy your later life*' and '*a great place to start and grow your business*'. The purpose of this document is to assist in achieving these goals by promoting good street design through development.

## 1.1.2 Document Status

The document has been prepared by the Council following two consultations on the draft and updated draft document between December 2018 and January 2019 and July 2020 and August 2020 respectively. The final consultation invited comments from; 35 developers; 85 transport consultants, architects, town planners, urban designers, associations or professional institutions; and 18 local authorities either within or neighbouring Nottinghamshire; amongst others. The draft document was also published for consultation on the County Council's website. Following the final consultation, the document was updated and subsequently endorsed by Communities and Place Committee on 3<sup>rd</sup> December 2020 and was approved by Policy Committee and became County Council policy on 13<sup>th</sup> January 2021.

1.1.3 A changes log can be viewed at Appendix A in order to provide an audit trail of material changes to the document following the final consultation.

1.1.4 Should you have a query with respect the content of the document, please call 0300 500 80 80 or email [hdc.north@nottsscc.gov.uk](mailto:hdc.north@nottsscc.gov.uk)

## 1.1.5 Introduction

There is already national guidance encouraging the creation of high-quality development and distinctive places such as Manual for Streets which is endorsed by the County Council. However, since the abolition of Design Bulletin 32, there is no national technical guidance that includes a comprehensive set of dimensions that can be used as reference when designing non-strategic road and street layouts that adequately accommodate people and places. Therefore, rather than replicate what is available nationally, this document's aim is to provide transport consultants, architects, town planners, urban designers, and developers with straight-forward highway design technical guidance and specifications for street works. National guidance is only repeated where it is necessary within this context. This document is not an urban design guide so can be read as a companion guide to the likes of Manual for Streets. It should not be seen as an alternative to Manual for Streets principles or other national guidance that is available or becomes available in the future. Engineering judgement will be applied when considering any submission but any relaxation to the guidance presented here will be considered with the discretion of the County Council and may need to be justified.

1.1.6 When considering proposals, the County Council will be mindful of the Equality Act 2010 and the public sector equality duty by having due *'regard to advancing equality of opportunity between persons who share a relevant protected characteristic and persons who do not share it'* including elderly people, disabled people, people of different gender, and children, and the Health and Public Care Act 2012 duty to improve public health by seeking to improve air quality and general public health and wellbeing.

1.1.7 The aim of the document is to achieve low speed neighbourhoods, that are safe, particularly for young children, that encourage a modal shift away from the private car, and in doing so, promote a healthy life style by encouraging walking and cycling.

1.1.8 Where street works are proposed outside of the scope of this document, these should be designed in accordance with the Design Manual for Roads and Bridges (DMRB) published by Highways England unless agreed otherwise. Should DMRB standards apply, the Council will adopt the role of the overseeing organisation.

1.1.9 It should be emphasised that works which directly affect the Strategic Road Network (SRN) will need to be considered separately by Highways England and are as such not bound by the contents of this document. The SRN both borders and runs through the County and certain locations interface directly with the Local Road Network. Highways England should be contacted at an early stage, on any proposals which will impact on the SRN (Trunk Roads and Motorways).

[End]



# Road Network Policy

## Part 1.2

### 1.2.1 Principles of access to the highway network

In order to facilitate new development, the County Council supports the need for limited improvements to 'A' and 'B' class roads, whether in improving or extending existing capacity, or providing new links, to address clearly identified significant strategic or local needs. In assessing proposals that would increase traffic, and/or provide new streets and junctions, the following criteria should be taken into account:

- the contribution to sustainable development and regeneration including improved connectivity;
- how conditions for pedestrians, cyclists, public transport users, freight and local residents can be improved;
- how safety for all is improved;
- the extent of any additional traffic and any effects it may have on the locality, and the extent to which congestion can be reduced; and
- how a net benefit to the environment can be provided.

1.2.2 Proposals should show, overall, a net benefit across these criteria when taken as a whole. All proposals must show how any dis-benefits will be mitigated.

1.2.3 New accesses for vehicles and the increased use of existing accesses on other classified and unclassified roads will normally be supported where:

- the needs of pedestrians, cyclists, public transport users, freight and local residents can be addressed;
- there is not a road safety problem or where a road safety problem can be removed;
- the route is suitable or can be suitably upgraded to carry the additional traffic and type of traffic from the development.

1.2.4 If access to a development can be gained off a minor or side street, you should normally consider this option as preferable (with improvements to the junction of the minor side street with the main road as necessary).

### 1.2.5 Need for Transport Assessments, Transport Statements, and Travel Plans

The National Planning Policy Framework 2019 (NPPF) covers the current national policy for promoting sustainable transport.

NPPF states that:

*“Planning policies should support an appropriate mix of uses across an area, and within larger scale sites, to minimise the number and length of journeys needed for employment, shopping, leisure, education and other activities”.*

1.2.6 The preparation of a Transport Assessment in support of a proposed development is identified as a key document in encouraging the use of more sustainable modes of transport. The NPPF goes on to say:

*“All developments that will generate significant amounts of movement should be required to provide a travel plan, and the application should be supported by a transport statement or transport assessment so that the likely impacts of the proposal can be assessed” ;*

1.2.7 Government guidance on the preparation of Transport Assessments, Transport Statements, and Travel Plans is provided in Planning Practice Guidance (PPG) ‘Transport evidence bases in plan making and decision taking’. The PPG states that

*“Where the transport impacts of development are not significant, it may be that no Transport Assessment or Statement or Travel Plan is required. Local planning authorities, developers, relevant transport authorities, and neighbourhood planning organisations should agree what evaluation is needed in each instance”.*

1.2.8 The ‘Guidance on Transport Assessment’ (GTA) (DfT, March 2007) was archived in October 2014. However, in lieu of any detailed replacement guidance being published, the County Council requires Transport Assessments and Statements to be prepared in accordance with the PPG and GTA, particularly where significant changes in traffic may occur.

1.2.9 In general, the County Council will seek a Transport Statement or a Transport Assessment and Travel Plan based on the following thresholds. These equate to development scenarios which would typically generate greater than 30 two-way peak hour vehicle trips. This threshold will also be used to establish the scope of the assessment in terms of main junctions to be included. However, there may be specific circumstances where the threshold requires adjustment both upwards and downwards. The scope of a Transport Assessment should therefore be agreed at an early stage. Lorry movements should be converted to Passenger Car Units (PCU) if likely to be material.

1.2.10 Where a proposed development meets the below thresholds but a change of use or change in access arrangements would not represent a material change in the level of traffic generation, the submission of a Technical Note may be sufficient in support of a planning application.

**Table T1.2**

Land use	Use/description of development	No assessment	Transport Statement	Transport Assessment and Travel Plan
Food retail	Retail sale of food goods to the public – food superstores, supermarkets, convenience food stores.	<250sq.m	>250<800sq.m	>800sq.m

Land use	Use/description of development	No assessment	Transport Statement	Transport Assessment and Travel Plan
Non-food retail	Retail sale of non-food goods to the public; but includes sandwich bars – sandwiches or other cold food purchased and consumed off the premises.	<800sq.m	>800<1,500sq.m	>2,500sq.m
Dwelling houses	Dwellings for individuals, families of up to six people living together as a single household and receiving care e.g. supported housing schemes such as those for people with learning disabilities or mental health problems.	<50 units	>50<80 units	>80 units
Business	Offices other than financial and professional services, research and development – laboratories, studios, light industry.	<1,500sq.m	>1,500<2,500sq.m	>2,500sq.m
General industrial	General industry other than 'Business'.	<2,500sq.m	>2,500<4,000sq.m	>4,000sq.m
Storage or distribution	Storage or distribution centres – wholesale warehouses, distribution centres and repositories.	<3,000sq.m	>3,000< 5,000sq.m	>5,000sq.m
Mixed Development/Sui Generis	Sui generis - For example: petrol filling stations, vehicle hire, vehicle sales, builders' yards, garden centres, scrap yards, waste disposal.	Discuss with highway authority		

Land use	Use/description of development	No assessment	Transport Statement	Transport Assessment and Travel Plan
Financial and professional services	Financial services – banks, building societies and bureaux de change, professional services (other than health or medical services) – estate agents and employment agencies, other services – betting shops, principally where services are provided to visiting members of the public.	<1,000sq.m	>1,000<2,500sq.m	>2,500sq.m
Restaurants and cafes	Restaurants and cafés – use for the sale of food for consumption on the premises, including internet cafés.	<300sq.m	>300<2,500sq.m	>2,500sq.m
Drinking establishments	Use as a public house, wine-bar or other drinking establishment.	<300sq.m	>300<600sq.m	>600sq.m
Hot food takeaway	Use for the sale of hot food for consumption on or off the premises.	<250sq.m	>250<500sq.m	>500sq.m
Drive-thru restaurants and coffee shops	Use for the sale of food and drink for collection in a vehicle and consumption off the premises.			In all cases
Hotels	Hotels, boarding houses and guest houses, development falls within this class if 'no significant element of care is provided'.	<75 bedrooms	>75<100 bedrooms	>100 bedrooms
Residential institutions-hospitals, nursing homes	Used for the provision of residential accommodation and care to people in need of care.	<30 beds	>30<50 bedrooms	>50 bedrooms

Land use	Use/description of development	No assessment	Transport Statement	Transport Assessment and Travel Plan
Residential institutions - residential education	Boarding schools and training centres.	<250 students	>50<150 students	>150 students
Residential institutions - hostels	Homeless shelters, accommodation for people with learning difficulties and people on probation.	<250 residents	>250<400 residents	>400 residents
Non-residential institution	Medical and health services – clinics and health centres, crèches, day nurseries, day centres and consulting rooms (not attached to the consultant's or doctor's house), museums, public libraries, art galleries, exhibition halls, non-residential education and training centres, places of worship, religious instruction and church halls.	<500sq.m	>500<1,000sq.m	>1,000sq.m
Assembly and leisure	Cinemas, theatres, dance and concert halls, sports halls, swimming baths, skating rinks, gymnasiums, bingo halls and casinos, other indoor and outdoor sports and leisure uses not involving motorised vehicles or firearms.	<500sq.m	>500sq.m<1,500sq.m	>1,500sq.m

### 1.2.11 Highway Adoption

We will encourage developers to create residential street layouts that are to an adoptable standard and that will be offered for adoption to protect residents' interests. We will not normally adopt access to developments of five or less dwellings. We will discourage the use of private streets serving in excess of five dwellings, and will consider whether the use of the Advanced Payment Code, Highways Act 1980 is appropriate to secure adoption in each case. In exceptional circumstances we may consider private streets serving in excess of five dwellings

subject to the Authority being indemnified from the cost of making-up streets and private maintenance arrangements being put in place.

1.2.12 For employment and commercial developments, we will not normally seek to adopt road layouts purely of an industrial or commercial nature unless a through route with wider strategic transport benefits.

[End]





# Hierarchy and Well-connected Streets

## Street Hierarchy

2.1 Levels of multimodal movement will vary throughout a place. Higher levels of activity would normally be expected near shops, schools, community facilities and around major corridors, whereas lower levels of activity might occur in minor residential streets and less formal areas. The standard of highway infrastructure should reflect this. Wider corridors will be required to accommodate wider footways around schools and shops, to incorporate cycling facilities, bus routes, and frequent lorry movements.

2.2 The preparation of plans are required to comply with the policies set out in the National Planning Policy Framework (2019) which says development should:

*a) give priority first to pedestrian and cycle movements, both within the scheme and within neighbouring areas; and second – so far as possible – to facilitating access to high quality public transport, with layouts that maximise the catchment area for bus or other public transport services, and appropriate facilities that encourage public transport use;*

*b) address the needs of people with disabilities and reduced mobility in relation to all modes of transport;*

*c) create places that are safe, secure and attractive – which minimise the scope for conflicts between pedestrians, cyclists and vehicles, avoid unnecessary street clutter, and respond to local character and design standards;*

*d) allow for the efficient delivery of goods, and access by service and emergency vehicles; and*

*e) be designed to enable charging of plug-in and other ultra-low emission vehicles in safe, accessible and convenient locations.*

Account should be taken of advice contained within *Planning Practice Guidance: Planning should promote safe, connected and efficient streets* (Paragraph: 008). The Urban Design Group's document *Building for a Healthy Life* principles are encouraged.

2.3 One of the main principles promoted by Manual for Streets (MfS) is to create networks of streets that provide permeability and connectivity to main destinations with a choice of routes. It is particularly important that the routes for walking and cycling are clear and direct and that bus routes do not become overly protracted. The overall hierarchy must therefore give priority to these modes of transport and consider the level of usage. The principle is to ensure that new development enhances the existing movement framework of an area rather than disrupting or severing it. MfS suggests that internal permeability is

important but that the area also needs to be properly connected with adjacent street networks because a development with poor links to the surrounding area creates an enclave which encourages movement to and from it by car rather than by other modes. MfS recommends that pedestrians and cyclists share streets with motor vehicles as this generally provides a more secure environment than connecting pathways as streets can more easily be designed to be overlooked with active frontages. Connected or permeable networks also lead to a more even spread of motor traffic throughout the area and so avoid the need for distributor roads with no frontage development. Furthermore, the avoidance of cul-de-sacs reduces the concentration of traffic on a smaller number of dwellings, negates the need for turning heads which are wasteful in land terms and lead to additional vehicle travel and emissions, particularly by service vehicles.

● Bus stop    ⇄ Principal routes    ⇄ Internal streets

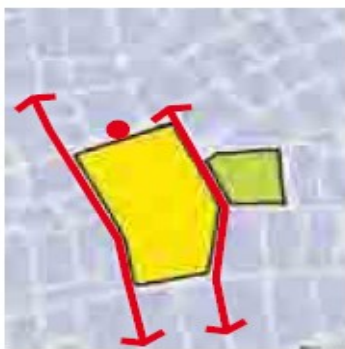

Consider how best the site can be connected with nearby main routes and public transport facilities.

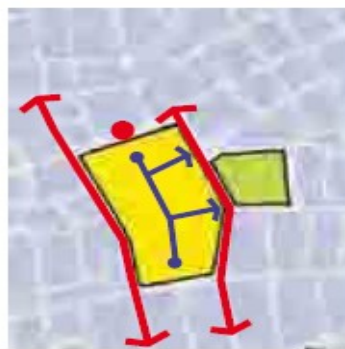

The typical cul-de-sac response creates an introverted layout which fails to integrate with its surroundings.



A more pedestrian friendly approach that integrates with the surrounding community. It links existing and proposed streets and provides direct routes to bus stops.

### Integrating new development into the existing urban fabric is essential



### Dispersed and car-dependent versus traditional, compact and walkable layout

#### Well-connected streets

2.4 New residential streets should be designed to form part of a well-connected street network (block structure). Well-connected street networks have significant advantages as:

- a shorter route can be used to cover a given area;
- reversing may be avoided altogether;

- they minimise land-take by avoiding the need for wasteful turning areas at the ends of cul-de-sacs;
- they encourage more people to walk and cycle to local destinations, improving their health while reducing motor traffic, energy use and pollution;
- more people on the streets leads to improved personal security and road safety. Research shows that the presence of pedestrians on streets causes drivers to travel more slowly;
- for utility companies – they provide space for service provision and alternative service routes;
- for highway and utility maintenance operations - traffic can be routed around a point closure if it is necessary to excavate the carriageway for maintenance.

2.5 Developers should aim to provide multiple points of vehicular access onto the wider highway network where land availability and where the external road network permits. These access points should be to adoptable standards and available for general public use. Where multiple points of vehicular access are not provided, the reasons for not doing so must be justified within the submission.

2.6 Cul-de-sacs may provide the only practical solution for developing awkward sites where the site is linear in nature, has difficult topography, boundary or other constraints and where through routes are not practical. Wherever possible cul-de-sacs should be avoided. However, it is accepted that they do have a role to play in some locations. Where this is the case, the opportunity to provide alternative more direct pedestrian and cycle routes should be explored in order to form a walkable neighbourhood. This would be characterised by having a range of facilities within 10 minutes' (up to about 800 m) walk.

2.7 If there is a likelihood that adjacent land will come forward that can be practically served through the development in the future, suitable ransom free connections should be provided to maintain and enhance the movement framework.

### **Bus Routes**

2.8 Larger developments must make provision for an efficient bus routing strategy as identified by way of Transport Assessment. We would support a bus route that serves the greatest majority of dwellings well (in excess of 80%) rather than one that serves all homes poorly with an indirect service. Affordable housing, and higher-density residential development should all be located within 400m of a bus stop, and preferably closer.

### **Emergency Access**

2.9 We will not normally seek emergency accesses because of:

- enforcement problems arising from their misuse;
- potential difficulties that could be encountered by the emergency services;
- maintenance issues and vandalism of access-control equipment; and
- general crime and anti-social behaviour problems.

2.10 Where there are valid reasons why at least two points of access cannot be achieved, and where the development proposal is otherwise acceptable to us, we may be prepared to consider an emergency access as long as:

- the emergency link is also of strategic benefit for pedestrians and cyclists;
- highway safety is not compromised and the access is not likely be a source of crime or anti-social behaviour problems;
- there are appropriate means of controlling its use;

- you have fully consulted the emergency services and the proposals are acceptable to them;
- the access is designed to accommodate safely all vehicles likely to use it; and
- long-term maintenance responsibilities are clearly defined and secured;
- A general width of 3.7m (minimum 3.1m at gates) is achievable, there is sufficient turning space for a fire appliance to manoeuvre, there is a minimum height clearance of 4.0m, and the weight carrying capacity is a minimum of 12.5 tonnes and 17 tonnes over structures (see Building Regulations – Fire Safety).

[End]

## General Geometry of Residential Streets

### Part 3.1

3.1.1 The guidance contained in this part is intended to help you design street layouts within a development where people wish to live, work, play, and feel safe doing so. You should select and assemble the design elements in table T3.1.1 that provide for the safe and free movement of all street users, including pedestrians, cyclists, bus passengers, and motorists, and which meet their movement requirements. Vehicle dominance should be restrained with the aim of creating an environment that is safe for everyone and that encourages people to walk, cycle, and use public transport.

**Table T3.1.1**

Street Type	Main Street	Residential Street	Residential Access Way(s)	Shared Private Drive	Single Private Drive
<b>Function</b> (Consult the highway authority with respect higher category roads)	Provides access from higher category roads or other Main Streets with at least two points of access to and from routes suitable for buses, forms the primary arterial access through a development, provides for the main conveyance of traffic within the development including commercial areas, designed to accommodate a bus route (Enviro 300 12.2m body on a SCANIA 'KUB' chassis), includes segregated provisions for cyclists.	Can connect to Main Streets or higher category roads and adjacent residential neighbourhoods with multiple points of access, provides links to the integrated public transport system, forms part of a block structure when within large developments.	Connect to streets with a design speed of up to 20mph only provide access to homes fronting the street with no wider motorised movement function, forms part of a block structure where practicable, not normally a cul-de-sac, does not provide access to land with the potential for further development outside of a walkable neighbourhood.	Private access, no wider movement function.	

Street Type	Main Street	Residential Street	Residential Access Way(s)	Shared Private Drive	Single Private Drive
<b>Number of dwellings</b>	No limit subject to Transport Assessment where applicable.	No limit provided part of a Walkable Neighbourhood subject to Transport Statement / Assessment where applicable.	Typically no more than 200 dwellings / 800m in total from local services, employment, and or 400m from bus stop(s). Forms part of a Walkable Neighbourhood.	Maximum 5 dwellings.	Normally a single dwelling but may serve two dwellings if street has no wider motorised movement function.
<b>Minimum carriageway width</b>	6.2m subject to vehicle tracking increasing to 6.5m passing schools, shops, and other areas of increased activity with an additional width of 2.5m for car parking or 2.75m for loading if on street parking is likely to occur (CIHT <i>'Buses in Urban Developments'</i> 2018).	Minimum of 5.5m unless also serving schools, shops, other areas of increased activity or on a bus route then refer to 'Main Street' dimensions.	Minimum of 5.0m or 5.5m if accessed from a Main Street or higher category road with a design speed in excess of 20mph.	4.8m width within 8.0m of the highway plus 0.5m clearance on both sides, additional width for bin storage.	Minimum 3.0m (3.6m if bound by walls) plus additional width for bin storage if serving two dwellings.
	A 9.0m minimum carriageway width will be required on bus routes where only a single point of access is available into a brownfield site from higher category roads. The internal layout should form a loop(s) at which point the carriageway may reduce as above.				
	Note: Where a street is to be narrowed, for example to help control vehicle speed, the minimum carriageway width (kerb to kerb) is 3.7m. The minimum lane width at a restriction, such as a pedestrian refuge in the middle of the road is 3.2m.				
<b>Quality Audit</b>	If a departure from guidance.		If a departure from guidance or shared surface (See Part 3.6 Shared Surfaces).	If a departure from guidance.	
<b>Access to schools</b>	Yes via a 'Residential Street'. No direct frontage access.	Yes, but not in a cul-de-sac.	No.		
<b>Target speed</b>	Up to 30mph (20mph near schools, within residential areas, parks and other areas of above average pedestrian activity particularly children).	Up to 20mph	Up to 15mph	N/A	

Street Type	Main Street	Residential Street	Residential Access Way(s)	Shared Private Drive	Single Private Drive														
<b>Turning Heads</b>	Should not be necessary in a well-connected network.		Required for cul-de-sacs in excess of 20m in length (see examples below) and always when accessed from a 'Main Street'.	Required.	Likely to be required on 'A' and 'B' class roads, high frequency bus routes, and other busy streets.														
<b>Carriageway centre-line radius</b>	Residential streets serving more than 25 dwellings that curve through more than 10 degrees.			N/A															
	<table border="1"> <thead> <tr> <th>Radius (m)</th> <th>20</th> <th>30</th> <th>40</th> <th>50</th> <th>60</th> <th>80</th> </tr> </thead> <tbody> <tr> <th>Min. widening (m)</th> <td>0.6</td> <td>0.4</td> <td>0.35</td> <td>0.25</td> <td>0.2</td> <td>0.15</td> </tr> </tbody> </table>			Radius (m)	20	30	40	50	60	80	Min. widening (m)	0.6	0.4	0.35	0.25	0.2	0.15		
Radius (m)	20	30	40	50	60	80													
Min. widening (m)	0.6	0.4	0.35	0.25	0.2	0.15													
	Widening should be on both sides of the curve, or on the inside for the length of the curve. Otherwise to be defined by tracking.																		
<b>Junction radii/dropped kerbs</b>	Usually 10m to be confirmed by vehicle tracking.	Usually 6.0m increasing to 10m on a bus route to be defined by tracking.	Usually 6.0m.	Dropped kerb the width of the access plus 2 kerbs 1:14 max gradient (7%).	Dropped kerb the width of the access or plus 2 kerbs if on a classified road or bus route 1:14 max gradient (7%).														
	Where width allows, a 900mm level surface should be provided at the back of the footway to aid mobility.																		

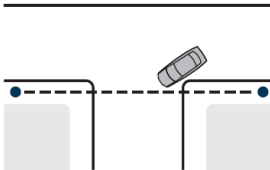
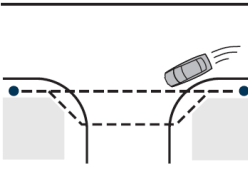
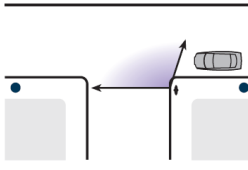
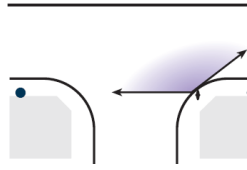
Street Type	Main Street	Residential Street	Residential Access Way(s)	Shared Private Drive	Single Private Drive
<b>Tight junction radii</b>	<p>Tight radii are acceptable in most circumstances subject to vehicle tracking. Goods vehicles and buses will normally be expected to be able to access and egress the side street without entering the opposing lane at busy junctions.</p> <div style="display: flex; justify-content: space-around; align-items: flex-start;"> <div style="text-align: center;">  <p>Pedestrian desire line (--) is maintained</p> <p>Vehicles turn slowly (10-15 mph)</p> </div> <div style="text-align: center;">  <p>Pedestrian desire line deflected</p> <p>Detour required to minimise crossing distance</p> <p>Vehicles turn faster (20-30 mph)</p> </div> <div style="text-align: center;">  <p>Pedestrian does not have to look far behind to check for turning vehicles</p> <p>Pedestrian can easily establish priority because vehicles turn slowly</p> </div> <div style="text-align: center;">  <p>Pedestrian must look further behind to check for fast turning vehicles</p> <p>Pedestrian cannot normally establish priority against fast turning vehicles</p> </div> </div>			N/A	
<b>Junction spacing and driveway position</b>	To be addressed by way of Transport Assessment.	Not normally within the visibility splay of an adjacent junction/access or within the visibility splay distance of a T-junction when in regular use. A crossroads would usually only be considered in a lightly trafficked area and will be treated as a special feature within a layout, opposite side roads should normally be staggered by at least 15m centres, and right/left staggers are preferable to left/right so as to reduce conflicting movements in areas of higher vehicle movement.		Not normally within twice the length of the junction radii on a Main Street or otherwise on radii (corners), at bus stops or lay-bys, close to refuges, close to traffic calming features, pedestrian crossings, or close to street furniture.	
<b>Junction approach</b>	Normally 90 degrees to priority road for at least twice the kerb radius length along the street centreline.			Normally 90 degrees to priority road.	
<b>Carriageway crossfall</b>	1:40 (2.5%)			N/A	
	Never connects to a street of less than 5.5m width.				



Street Type	Main Street	Residential Street	Residential Access Way(s)	Shared Private Drive	Single Private Drive
<b>Carriageway longitudinal gradient</b>	Flexible surfacing: minimum 1:100 (1%) maximum 1:20 (5%). Never to exceed 1:25 (4%) for the first 10m of a junction.		Flexible surfacing: minimum 1:100 (1%). Block surfacing: minimum 1:80 (1.25%). Maximum 1:20 (5%). Never to exceed 1:25 (4%) for the first 10m of a junction.	Preferably $\leq$ 1:20 (5%) Maximum 1:12 (8%) up to 5 dwellings else see Residential Access way.	
	Prior approval will be required to vary these gradient parameters where it can be demonstrated that they are not feasible on particularly challenging sites. A relaxation may be acceptable where an alternative pedestrian route is available.				
<b>Carriageway vertical curves</b>	See: Vertical Curves			N/A	
<b>Visibility splays at junctions, 'Y' distance also applicable on bends and vertical crests</b>	Minimum 2.4m (X) x 47m (Y) or 2.4m (X) x 27m (Y)	Minimum 2.4m (X) x 25m (Y) or 27m (Y) if on a bus route.	Minimum 2.4m (X) x 17m (Y).	See road type.	
	Visibility splays to be kept clear within an envelope between a height of 0.6m and 2.0m above carriageway level. For existing streets and roads (see: Visibility Splays). Forward visibility splays are usually only required on bus routes and on higher category roads.				

Street Type	Main Street	Residential Street	Residential Access Way(s)	Shared Private Drive	Single Private Drive
<b>Service strips</b>	2.0m usually combined with footway (see verges).		2.0m in footway.	N/A	
<b>Carriageway margins</b>	Only acceptable where there is no frontage development, no pedestrian desire line and/or a route required for utility services. Minimum 0.6m increasing to 0.75m if containing street lighting.			N/A	
<b>Verges</b>	To be assigned to dwellings. Not normally on flank frontages. To be located to the rear of foot or cycle ways. Minimum 1.0m wide minimum 10sq.m otherwise hard paved. Minimum of 2.0m if containing services.			N/A	
<b>Footway width</b>	Usually 2.0m minimum width on both sides of the carriageway. Minimum 3.0m outside schools and bus stops (0.5m minimum clearance between bus shelters and carriageways). Minimum 4.0m in shopping areas.	Usually 2.0m minimum width on both sides of the carriageway.		N/A	
<b>Footway gradients</b>	Longitudinal Gradient Minimum 1:100 (1%). Longitudinal Gradient Maximum 1:20 (5%). Maximum cross-fall 1:35 (2.85%), Maximum 1:14 (7%) at driveways with a 25mm kerb upstand. Where the width allows vehicular crossings should include 900mm of footway with a maximum 1:35 (2.85%) cross-fall. Prior approval will be required to vary these gradient parameters where it can be demonstrated that they are not feasible on particularly challenging sites. A relaxation may be acceptable where an alternative pedestrian route is available.			N/A	
<b>Walkable neighbourhoods</b>	Appropriate pedestrian provision to local services, and areas of employment with a typical catchment of around 800m, or a 10 minute walk (CIHT 'Planning for Walking' 2015).				
<b>Pedestrian visibility splays at accesses see: Visibility Splays – Part 3.3</b>	Minimum 2.0m x 2.0m adjacent footways where the footways are ≤ 3.0m or within 50m of schools, shops, areas of high pedestrian activity.	Minimum 2.0m x 2.0m when within 50m of schools, shops, areas of high pedestrian activity, and from shared private drives where the footways are ≤ 3.0m else not required.	Not required.	As per road type.	
Pedestrian visibility splays may be required where footways are absent.					

Street Type	Main Street	Residential Street	Residential Access Way(s)	Shared Private Drive	Single Private Drive
<b>Crossings</b>	The normal basic requirement is to provide dropped kerbs with buff coloured tactile paving. Where a refuge in the middle of the road is required, this must be 2.0m wide for pedestrian only use or 2.5m wide where it will be used by cyclists. The refuge must allow 4.0m of carriageway clearance on both sides to allow vehicles to pass cyclists or 3.2m where this is not considered necessary. In large developments it may be necessary to consider some form of light-controlled crossing such as a Zebra, PELICAN or TOUCAN.			N/A	
<b>Bus service</b>	Required subject to Transport Assessment.	May be a bus route.	Not suitable for buses.	N/A	N/A
<b>Bus access</b>	Bus stop locations between 250m and 400m maximum walking distance with 300m to 400m intervals between stops.	80% of dwellings to be within 250m to 400m maximum walking distance of a bus stop location where there is an existing or to be secured route (See Part 2.0 Hierarchy).		N/A	N/A
	In rural areas the walking distance should not be more than 800m				
	Single points of access should be avoided when bus access is required. Where this is not possible and the development is otherwise deemed acceptable, a minimum carriageway width of 9.0m is required to maintain access during essential maintenance.				
<b>Bus Stops</b>	To include real time bus stop poles & displays including associated electrical connections, shelters, lighting and timetable cases and bus stop clearways. 180mm raised kerbing height for 4m min. 3m min. footway width. Lay-bys only where many people will want to board. To be suitably located to minimise the effect of any vertical deflection traffic calming on passenger entering/leaving a bus to/from a seated position.		N/A	N/A	
<b>Bus Frequency</b>	Target every 30 minutes minimum day time services, evenings and weekends minimum hourly. The service frequency and days/times of operation will depend upon the local network including the demand for travel, the commercial status of the service, and the potential for the service to become financially sustainable.			N/A	
<b>Cycleway</b>	Yes	Yes if part of wider internal network.	No but may require pedestrian / cycle links.	No	
	Must comply with Department for Transport LTN1/20 'Cycle Infrastructure Design'.				

### 3.1.2 Turning Heads

Where cul-de-sacs are unavoidable, entrances to premises or private drives should be located at the ends of turning heads in order to discourage parking. The size of the turning head should be determined by the expected type of vehicles. In a residential area, this would usually be sufficient to accommodate a full sized dust cart 11.5m – 12m long (see figure below). The turning head may be contained within a street junction when not a Main Street. The blue shaded areas in the below diagrams are required for vehicle overhang and must be included as part of the highway. These can form all or part of a footway. Where larger vehicles are likely to be frequent, it may be necessary to incorporate a larger turning head. It is not necessary to construct the turning head in the precise shape shown in these diagrams, or even to distinguish it by means of surface demarcation. It is simply necessary to demonstrate that the space provided is appropriately laid out to accommodate the size of vehicle consistent with the type of development by way of vehicle tracking. Turning heads can be 'disguised' to avoid them becoming a dominant presence in a street.

#### Residential Turning Heads

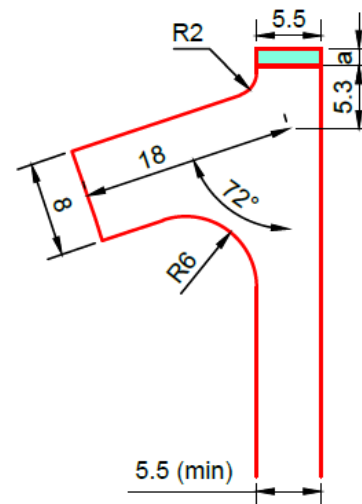
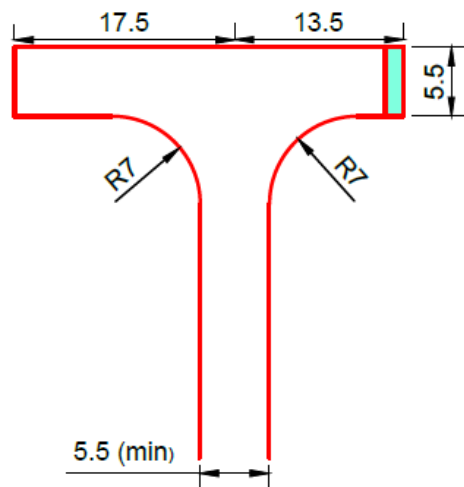

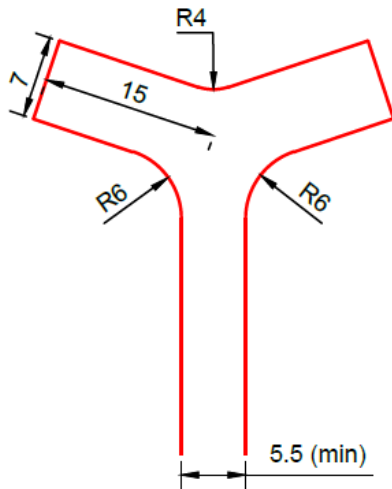
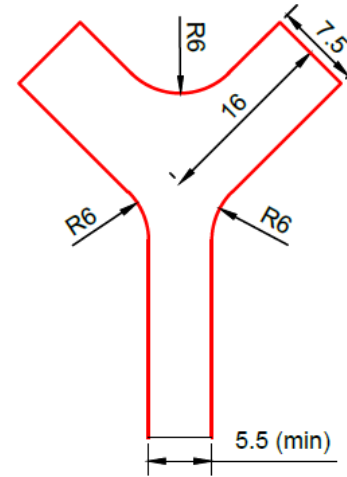
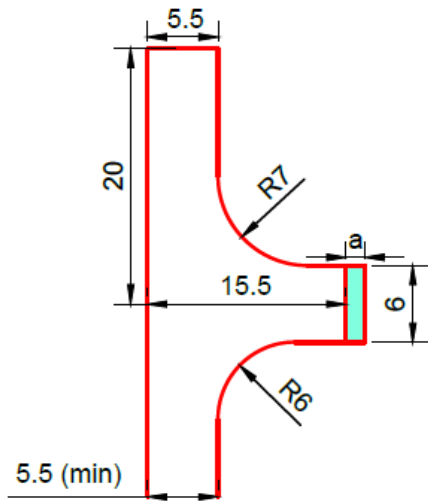

Area of possible vehicle overhang where 'a' = 1.5m

[End]



# General Geometry of Commercial and Industrial Estates and Premises

3.2.1 The guidance contained in this part is intended to help you design industrial and commercial street layouts that provide for the safe and free movement of all street users, including pedestrians, cyclists, bus passengers, and motorists, and which meet their movement requirements. You should select and assemble the design elements in table T3.2.1 with the aim of creating an environment that is safe for everyone and that encourages people to walk, cycle, and use public transport.

**Table T3.2.1**

Geometry Requirements for Industrial/Commercial Roads				
Road type	Major industrial access road	Minor industrial access road	Access to Premises	
<b>Function</b>	Large Retail (supermarkets), General Industry, Warehouse / Distribution	Offices / Light Industry and Assembly and Leisure	All	
<b>Size</b>	No limit subject to Transport Assessment (TA). Must include multiple points of access with provision for cyclists and buses.	No limit subject to TA provided all employment units are within a 400m maximum walking distance of a bus stop.	Usually a single point of access subject to TA depending on scale	
<b>Target speed</b>	30mph	25mph	N/A	
<b>Minimum carriageway width</b>	7.3m	6.0m for offices and assembly and leisure uses 6.75m for light industry.	N/A	
<b>Carriageway centre-line radius and widening on bends</b>	55m minimum			
	Radius (m)	55 to 74	75 to 89	90 to 150
	Min. widening (m)	1.2	0.7	0.6
Widening should be on both sides of the curve, or on the inside.				

## Geometry Requirements for Industrial/Commercial Roads

Road type	Major industrial access road	Minor industrial access road	Access to Premises
<b>Junction radii</b>	See Design Manual for Road and Bridges CD123 Else subject to vehicle tracking.		Usually a minimum 10m wide entrance 15m dropped kerb when across a 2.0m wide footway. Else radius kerbs
<b>Junction spacing</b>	90m on the same side of the road that maybe reduced to 60m if the priority road is speed restrained unless it can be demonstrated by way of speed-readings that short stagger distance would remain adequate. 40m on opposite sides.		Not within twice the junction radii
<b>Junction approach</b>	Wherever possible 90 degrees to priority road for at least twice the kerb radius length along the centreline.		Wherever possible 90 degrees to priority road.
<b>Turning heads</b>	Not normally required if more than one point of access.	In accordance with Freight Transport Association publication 'Designing for Deliveries'.	
<b>Carriageway crossfall</b>	1:40 (2.5%)		N/A
<b>Carriageway/access longitudinal gradient</b>	Flexible surfacing: minimum 1:100 (1%) maximum 1:20 (5%) Not to exceed 1:25 (4%) for the first 10m of a junction		Not to exceed 1:25 (4%) for the first 10m of a junction
<b>Carriageway vertical curves</b>	See: Vertical Curves		N/A
<b>Visibility splays at junctions, 'Y' distance also applicable on bends and vertical crests</b>	Minimum 2.4m (X) x 59m (Y)	Minimum 2.4m (X) x 47m (Y)	As per road type from 2.4m minimum setback (X distance)
	Speed-readings may be required from existing roads to establish visibility splay length.		
<b>Service strips</b>	2.0m usually combined with footway (see verges)		N/A

<b>Geometry Requirements for Industrial/Commercial Roads</b>			
<b>Road type</b>	<b>Major industrial access road</b>	<b>Minor industrial access road</b>	<b>Access to Premises</b>
<b>Carriageway margins</b>	0.5m increasing to 0.75m if containing street lighting (Development on opposite side of the road only)		N/A
<b>Verges</b>	Not normally acceptable in the highway		N/A
<b>Footway width</b>	Usually 2.0m minimum width on both sides of the carriageway		N/A
<b>Footway pinch points</b>	Minimum 1.2m for a maximum length of 6.0m		N/A
<b>Footway gradients</b>	Minimum 1:100 (1%), Maximum 1:20 (5%) Maximum crossfall 1:35 (2.85%) Maximum 1:14 (7%) at accesses		
<b>Pedestrian visibility splays at access</b>	2.0m x 2.0m		
<b>Bus stops</b>	To include real time bus stop poles & displays including associated electrical connections, shelters, lighting and timetable cases and bus stop clearways. 300m – 400m interval 180mm raised kerbing height for 4m min. Lowered kerbs for access 3m min. footway width To include shelters, lighting, real-time displays, timetable cases, & bus stop clearways		N/A
<b>Bus frequency</b>	Target every 30 minutes minimum day time services, evenings and weekends minimum hourly		
<b>Cycling facilities</b>	To comply with Department for Transport LTN 1/20		

[End]





## Stopping Sight Distance (SSD)

SSD is calculated using the following equation:

$$\text{SSD} = vt + (v^2/2(d+0.1a))$$

v = speed (or velocity) (m/s) (85%ile wet-weather measured speed)

**Note: Dry-weather speeds can be converted by adding 4kph**

t = driver perception-reaction time (s)

t = 1.5s if  $\leq 37$  mph (60 kph) 85%ile wet-weather measured speed

t = 2.0s if  $\geq 37$  mph (60 kph) 85%ile wet-weather measured speed

d = deceleration (m/s<sup>2</sup>)

d = 4.41 m/s<sup>2</sup> if  $< 5\%$  HGVs

d = 3.68 m/s<sup>2</sup> if  $> 5\%$  HGVs or bus lane

d = 2.45 m/s if  $\geq 37$  mph (60 kph) 85%ile wet-weather measured speed

a = longitudinal gradient (%) (+ for upgrades and – for downgrades)

### *Example <5% HGVs*

*37mph measured wet weather speed  $\times 2.237 = 16.54\text{m/s}$  velocity*

$$16.54 \times 1.5 = 24.81$$

$$16.54^2 = 273.58$$

$$2 \times 4.41 = 8.82$$

$$8.82 + (0.1 \times 5) = 9.32 \text{ (5\% uphill gradient)}$$

$$273.58 \div 9.32 = 29.35$$

$$24.81 + 29.35 = 54.16$$

$$54.16 + 2.4 = \underline{56.56\text{m}} \text{ (visibility splay adjusted for bonnet length)}$$

3.3.1 Speed is either a design parameter or a measured value. Deceleration depends on the road surface and weather conditions as well as the braking capabilities of motor vehicles. Reaction times may increase on higher speed roads because there are usually fewer visual influences. It is inappropriate for designers to 'experiment' with these values without this being supported by credible rationale and risk assessment. It follows that for design purposes it is only speed (v) and gradient (a) that really need to be considered as variables in the SSD equation.

### Stopping sight distance guidance table for speeds < 60km/h

Speed	kph	16	20	24	25	30	32	40	45	48	50	60
	mph	10	12	15	16	19	20	25	28	30	31	37
SSD adjusted for bonnet length nil gradient ('Y' & 'V' Distance (m))		11	14	17	18	23	25	33	39	43	45	59
SSD adjusted for bonnet length nil gradient > 5% HGVs ('Y' & 'V' Distance (m))		12	15	19	21	25	27	37	43	47	50	65

### Stopping sight distance guidance table for speeds > 60km/h

Speed	kph	70	85	100	120
	mph	43	53	62	75
SSD ('Y' & 'V' Distance (m))		120	160	215	295

## Visibility Splays

### Visibility Splays at Junctions

3.3.2 SSD is the 'major road distance' for junction visibility (Y-distance). The minimum 'minor road distance' is 2.4m in a built-up area based on drivers being able to see along the street without their vehicles intruding into the carriageway (X-distance). Nothing shall be planted within 1.0m of the visibility splays if there is potential for the visibility splays to be encroached upon by vegetation during periods of rapid growth.

3.3.3 Where speed exceeds 60 km/h, the minimum X-distance is 2.4m for simple priority junctions. For all other priority junctions, the X-distances is 4.5m. The X-distance, from which the full Y-distance visibility is provided, shall not be more than 9.0m, as this encourages high minor road approach speeds into the junction, and leads to excessive land take.

**Note:** Visibility splays must be either within the public highway or over land in the control of the developer to ensure that they remain free from obstruction whilst ever the development remains in existence.

## Visibility Splay at Junctions and Direct Accesses

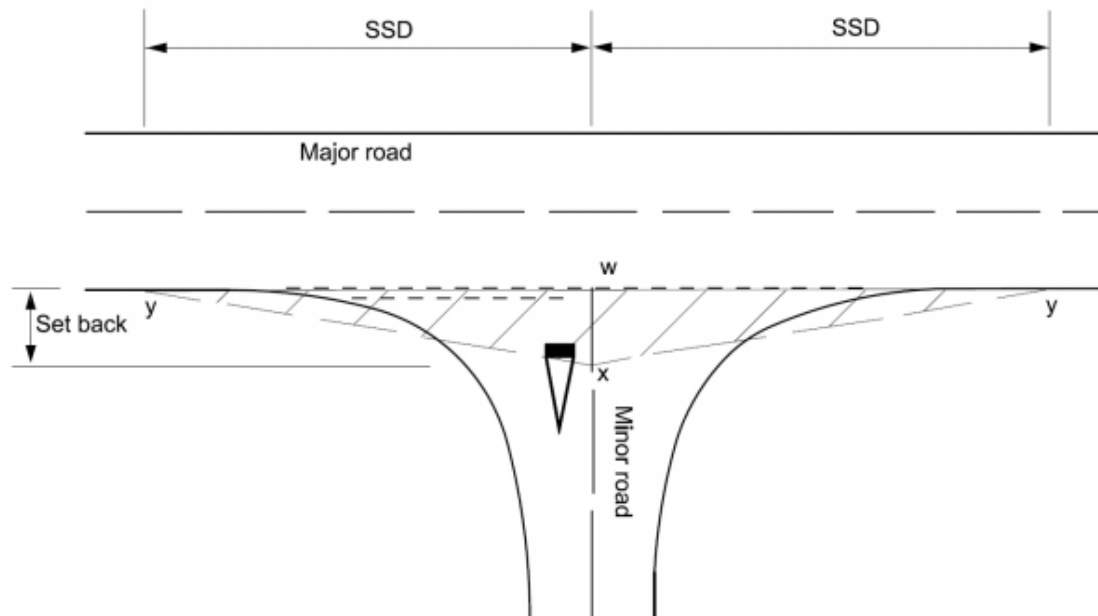

Note: 'W' corresponds to the intersection point between the minor road or access centreline and the major road edge of carriageway

## Visibility Splay for a Junction or Direct Access on the Outside of a Bend

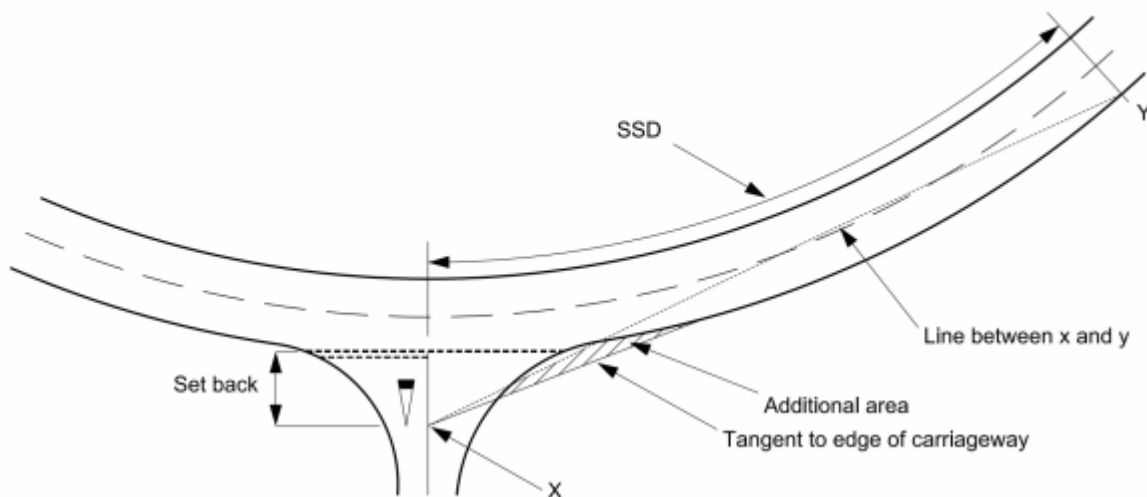

Where the line between points X and Y falls partially within the major road carriageway, an additional area shall be added to the visibility splay formed by drawing a line from X to a point tangential to the nearer edge of the major road running carriageway.

## Vertical Visibility Envelope

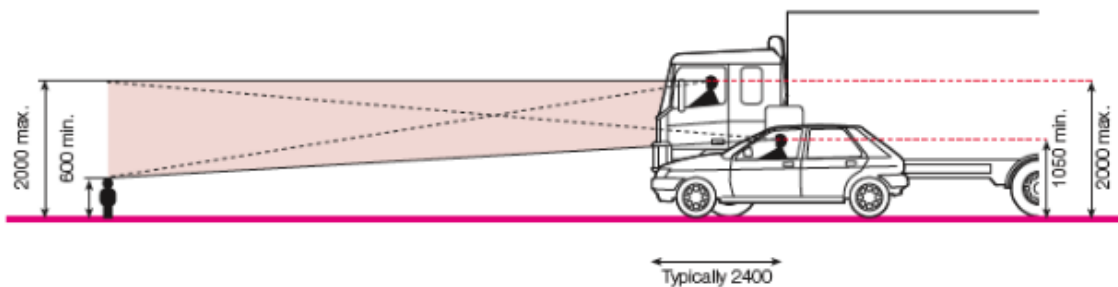

3.3.4 To enable drivers to see a potential hazard in time to slow down or stop comfortably before reaching it and to have sufficient visibility of oncoming vehicles from side streets and accesses, it is necessary to consider the driver's line of vision, in both the vertical and horizontal planes. A height of 600mm should be available above which unobstructed visibility should be provided wherever the potential exists for conflicts between motorists, and motorists and pedestrians. This will reduce to 0.26m where the speed of traffic is >60kp/h.

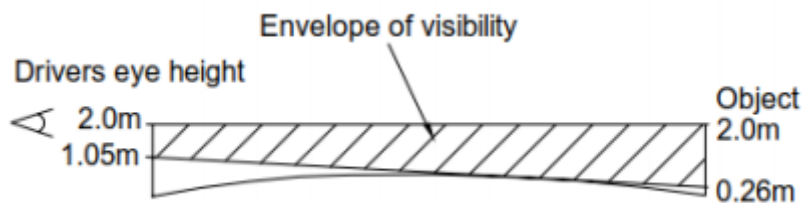

**Priority junction and direct access offside visibility splay on a curved major road**

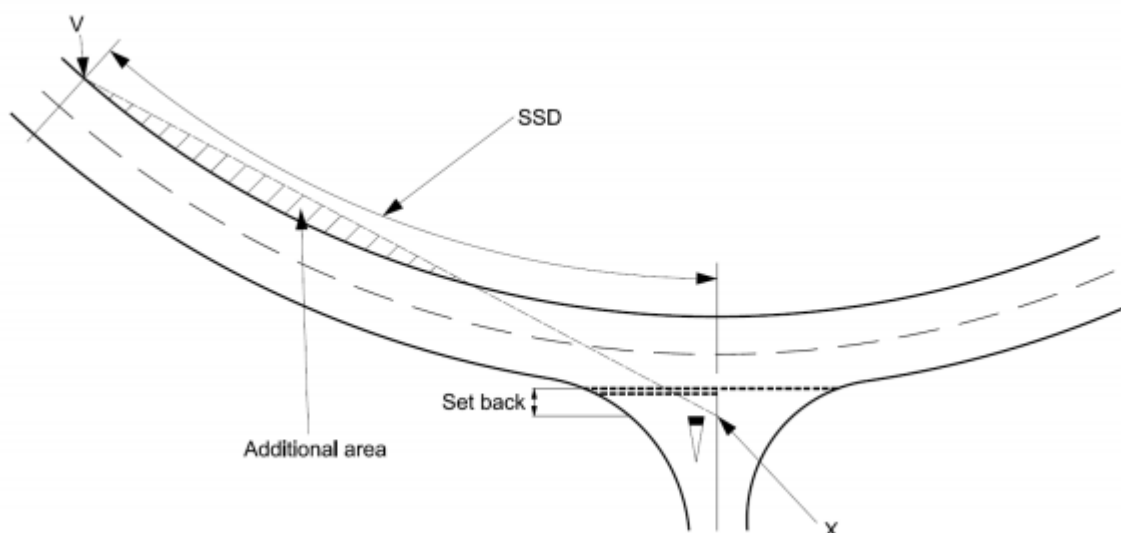

**Forward Visibility Splays**

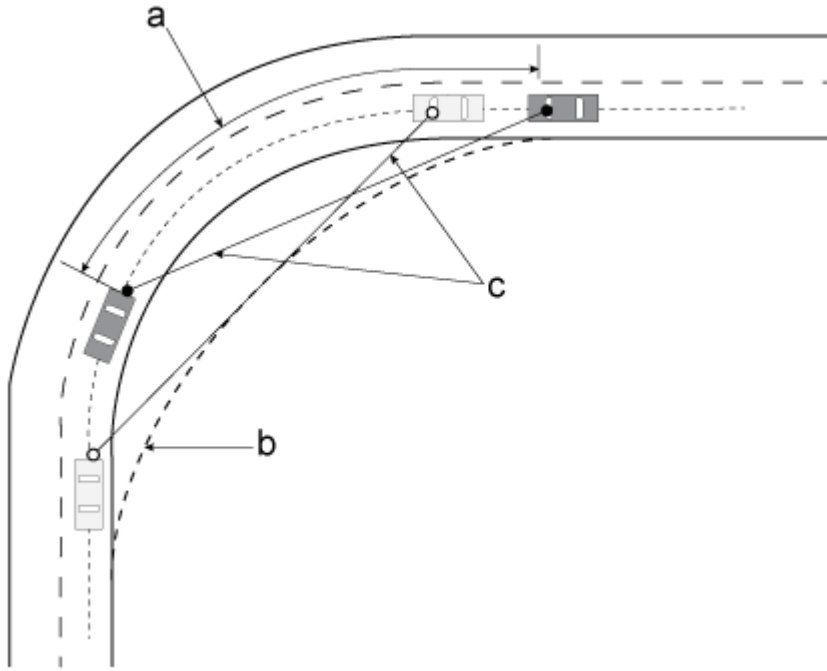

3.3.5 Forward visibility is the distance a driver needs to see ahead to stop safely to avoid an obstruction in the road. The minimum forward visibility required is equal to the minimum SSD. It is checked by measuring between points on a curve along the centreline of the inner traffic lane where 'a' is the forward visibility measured along the centre of the inner lane, 'b' is the visibility splay envelope, and 'c' is the visibility splays.

### **Pedestrian Visibility Splays**

3.3.6 Pedestrian visibility splays will commonly be required adjacent private accesses in areas of moderate to high pedestrian activity. This is usually achieved by setback walls or fences.

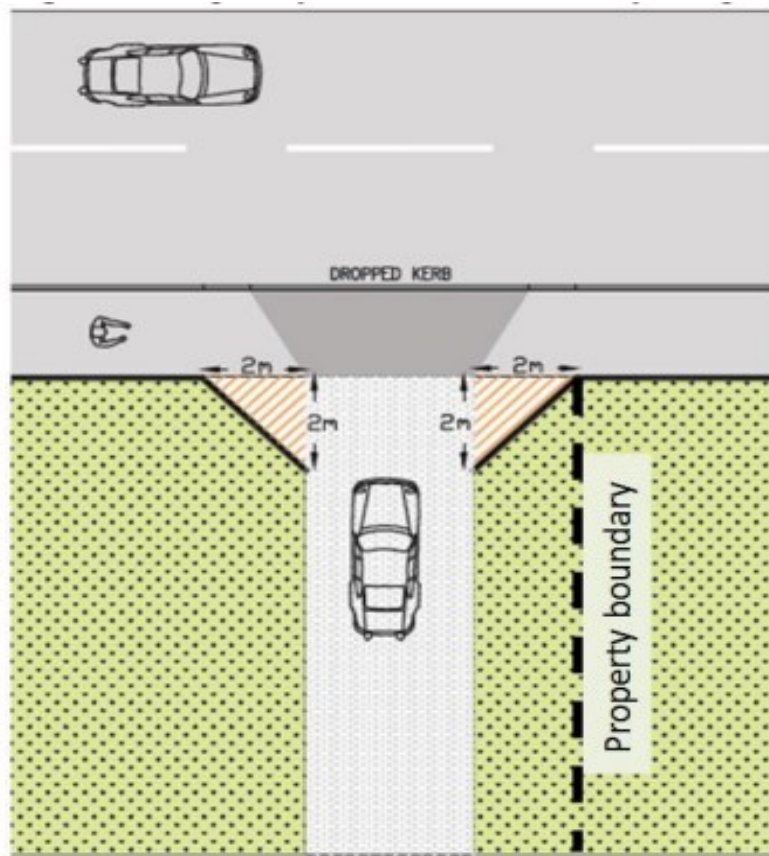

A vehicle emerging from a driveway at the back edge of a footway will require the driver to consider the possible presence of pedestrians. The absence of pedestrian visibility splays may encourage drivers to emerge more cautiously. Consideration should be given as to whether the absence of splays is appropriate, taking into account the frequency of vehicle movements, the amount of pedestrian activity, and the width of the footway.

[End]



# Vertical Curves

Where changes in gradient occur, vertical curves will be required at sags and crests. Except where indicated in the following notes, curve lengths should normally be either:

- the sum  $K \times A$ , where  $K$  is given in below table and  $A$  is the algebraic difference of the gradients expressed as a percentage; or
- the minimum length for appearance stated in the table;

whichever is the higher.

### Example of a vertical curve calculation



Gradient exaggerated for illustrative purposes

#### Calculation

For a 20mph design speed  $K = 3$  (from table)

Algebraic difference of gradients expressed as a percentage ( $A$ ) = 3 minus -5.0 (from diagram above) = 8

Curve length = 3 (from table) x 8 = 24m

(greater than minimum length for appearance from table (20m))

Table T3.4.1 - Vertical curves for all internal roads

85 <sup>th</sup> %ile design speed (mph)	Minimum length of vertical curve (K)	Minimum length of vertical curve for appearance (metres)
30	6.5	30
25	4	25
20	3	20
15	2	20

## Notes

- You should hold early discussions with us for large, flat sites to ensure that the vertical alignment is acceptable. In some cases, it may be necessary to provide combined kerb and drainage units to ensure both an acceptable alignment and drainage of the highway.
- For crests, it may be necessary to increase the length of vertical curve derived in order to achieve the required forward visibility distance.
- We may accept shorter curve lengths where there are exceptional difficulties in achieving the length normally required.
- To avoid stretches of road where water gathers, do not apply the minimum length where **A** is less than five on any sag curve that results in a low point on the road.
- Speeds on new residential development roads should normally be restricted to 20mph or less.

[End]





# Speed Restraint

3.5.1 In accordance with the requirements of Part 3.1 of this guide, 'Geometry of Residential Streets' we will require all new streets to achieve target design speeds of between 15 and 30mph depending on their classification.

In order to achieve the required target speeds we would in the first instance encourage traffic calming through good design by the omission of long straights, large radius curves, large forward visibility splays, and limiting the lengths of street.

The use of vertical displacement measures (cushions/humps) should only be considered as a last resort. Due to resultant problems with errant parking, the County Council would not usually accept the use of chicanes as traffic calming features.

Maximum distance between traffic calming features		
Target Speed		Maximum distance (m)
kph	mph	
50	31	150
40	25	100
30	19	60
25	16	40

## Speed control humps

3.5.2 Other than on bus routes, speed control humps must be flat topped humps or junction tables with a minimum plateau length of 7m and height of 75mm. Approach ramps should normally have a gradient of 1 in 13. Where the carriageway has a longitudinal gradient approaching the maximum allowed then the "uphill" ramp gradient should be 1 in 15 and the "downhill" ramp gradient should be 1 in 13.

3.5.3 Humps and tables must be constructed in bituminous material (unless used on a block-paved carriageway or shared surface where they should be constructed in the same material as the carriageway), using 55%/10mm medium temperature asphalt to BS 594 column 3/4 unless otherwise agreed.

3.5.4 We will require the payment of commuted sums to cover the future maintenance of speed control humps and similar vertical traffic calming measures.

## Public consultation

3.5.5 The addition of speed restraints within the existing public highway is likely to require a public consultation exercise for which you will be responsible for the cost of the consultation. The successful outcome of consultations is not guaranteed and therefore may dictate a redesign.

## **Entry ramps**

3.5.6 Entry ramps should normally have a gradient of 1 in 13 and a height between 75mm and 100mm. Granite set rumble strips will only be considered in exceptional circumstances due to problems associated with noise and maintaining integrity.

## **Bus routes**

Any vertical deflection traffic calming must be suitably located to minimise the effect on passenger entering/leaving a bus to/from a seated position.

[End]



# SHARED SURFACE OR SHARED SPACE STREETS AND SQUARES

## Foreword

3.6.1 The provision of shared surface streets has been inspired by documents such as 'Manual for Streets' where the emphasis has been on achieving an improved 'place' function. The County Council will adhere to the principle that street design needs to be inclusive to meet the requirements of all users. This may be best achieved by providing safe corridors for pedestrians. For many years this has been successfully achieved by providing footways. This document is not intended to endorse or encourage any other approach.

## Concept

3.6.2 In traditional street layouts, footways and carriageways are separated by a kerb. In a street with a shared surface, this demarcation is absent so pedestrians and vehicles can share the same space. Shared surface schemes work best in calm traffic environments with the following key aims:

- to encourage low vehicle speeds;
- to create an environment in which pedestrians can walk, or stop and chat without feeling intimidated by motor traffic;
- make it easier for people to move around; and
- to promote social interaction.

3.6.3 Department for Transport Local Transport Note 1/11 (currently suspended) defines a shared space as:

*"A street or place designed to improve pedestrian movement and comfort by reducing the dominance of motor vehicles and enabling all users to share the space rather than follow the clearly defined rules implied by more conventional designs".*

## Design principles

3.6.4 Whilst the County Council would consider a shared surface street layout whether a road is to be adopted or not, this is not the same as providing a road but omitting a footway or footways. Should the applicant wish to pursue the principle of a shared surface street, the County Council will require the application to be supported by a Quality Audit <sup>(a)</sup> as outlined in Manual for Streets, Manual for Streets 2: Wider Application of the Principles, Local Transport Note 1/08 and Traffic Advisory Leaflet 5/11 demonstrating that the requirements of non-motorised users have been considered and satisfactorily addressed.

3.6.5 Shared surface arrangements must be designed such that they are suitable for blind or partially-sighted people because conventional kerbs are commonly used to aid their navigation. The absence of a conventional kerb may pose them problems as this feature is often used to find their way around. It is therefore important that shared surface schemes include an alternative means for visually-impaired people to navigate by.

3.6.6 When designing shared surface schemes, careful attention to detail is required to avoid other problems, such as:

- undifferentiated surfaces leading to poor parking behaviour;
- vulnerable road users feeling threatened by having no space protected from vehicles; and
- the positioning and quantity of street lighting, street furniture and other features creating visual clutter.

3.6.7 Subject to making suitable provision for disabled people, shared surface streets may be considered:

- in short lengths, or where they form cul-de-sacs; and
- where parking is controlled, or it takes place in designated areas.

### **Types of shared surface streets**

3.6.8 Shared surface streets may have physically demarcated pedestrian routes or protected zones for pedestrians or a level surface.

#### **Shared surface streets with designated pedestrian routes**

3.6.9 Shared surface streets with a designated pedestrian route are those where the separation between carriageway and footway is reduced and the difference between the vehicle track, where vehicles are permitted, and the area set aside for pedestrians only is less physically distinct than a standard footway and carriageway separated by a kerb.

3.6.10 In these streets it will be necessary for part of the street to be kept free of traffic and hence for the sole use of pedestrians. This protected zone can be defined by a range of measures subject to agreement with the County Council. Typical measures include kerbs, textured surface and colour contrast providing a continuous demarcation between the shared zone and the protected zone to aid navigation for people with a visual impairment and helping to control vehicle movements. A range of other features may be considered to supplement and support the function of the protected space. All are likely to be subject to payment of a commuted sum.

The designated pedestrian route should be free from car parking and adequately provide way finding methods which are suitable for the blind and partially sighted.

#### **Shared surface streets without a protected zone**

3.6.11 Level Surface Streets are a kind of shared space where there is no vertical differentiation thereby providing a single shared surface. Level surface streets are only appropriate for short stretches in locations with low to very low vehicle flows and speeds which should be self-enforcing through good design.

3.6.12 The needs of different groups of people need to be considered, including disabled people (e.g. mobility impaired, blind / partially sighted, hearing impaired), children, and elderly people. This street type is not suitable to serve developments predominantly housing older or disabled people, e.g. housing for over 55s and supported or sheltered housing.

## Notes

### a) **Quality Audit**

Each application that includes a shared surface street will require supporting by a quality audit. The scope of the audit should be agreed with the County Council and potentially the local planning authority should they wish the audit to address planning matters. Depending on the nature of the development, the quality audit is likely to be required to include the following;

- a review of the function of the street;
- a road safety audit including risk assessment (DMRB GG119);
- an access audit including emergency service vehicles, deliveries, and access for maintenance (Traffic Signs Manual Chapter 8 - Traffic Safety Measures and Signs for Road Works and Temporary Situations);
- walking, cycling and horse-riding assessment and review (DMRB GG142);
- materials audit;
- equality impact assessment;
- parking audit;

### b) **Tactile Paving**

Tactile paving is required at crossing points regardless of whether kerbs are dropped or the carriageway is raised to footway level. Other tactile information may be required to compensate for kerb removal elsewhere. Where tactile delineators are used to segregate protected zones, care must be taken to ensure these are detectable by the visually impaired whilst not hindering the movement of the mobility impaired.

### c) **Surface Treatment**

*MfS: Shared surface streets are often constructed from pavements rather than asphalt, which help emphasise their difference from conventional streets. Research for MfS has shown that block paving reduces traffic speeds by between 2.5 and 4.5 mph, compared with speeds on asphalt surfaces.*

Shared surface streets should differ in colour or texture (preferably both) from that of adjoining streets, and must always be entered via a gateway feature.

## **Making Provision for Utility Services**

There are no statutory obligations governing the position or depth at which apparatus should be laid within the highway. On new development sites where utility apparatus is to be installed, the NJUG guidelines for the positioning and colour coding of underground apparatus should be followed. Any deviation from these guidelines should only be conducted with the agreement of the prospective asset owners and the County Council. With the exception of essential road crossings, mains utility services should not be located in the carriageway unless the carriageway is a shared surface designed with an area to accommodate utility apparatus.

In shared surface streets, apparatus will normally be accommodated within 2.0m minimum width service strips. Services will usually be laid on the side of the street with the most properties with branch crossings serving properties on the opposite side. It will not normally be necessary to provide a 2.0m service strip on both sides of the street. It is the developer's responsibility to provide cross carriageway ducts.

It is essential that only planting with a shallow root system (usually grass) is located within service strips. Where a service strip is to accommodate existing vegetation, it must be wide enough to avoid damage to existing root systems. Banks or mounds should not encroach onto service strips and levels should not be altered over existing apparatus without prior consent from the respective undertakers affected.

Mains services must be provided in a manner whereby repair and maintenance can be carried out without obstructing passage. Service strips must be appropriately delineated, and developers must make it clear to purchasers that the service strip is not conveyed to the property. However, the maintenance responsibility for service strip planting may be assigned to individual properties in their deeds.

Where the provision for services is not well defined, the street layout should be agreed with the County Council at pre-planning application stage to avoid unnecessary delay to the planning process and potential redesign.

[End]

# Quality Audit

## Part 3.7

### Purpose

3.7.1 A quality audit is intended to be a consistent method in reaching agreement on how a proposal complies with the principles of design guidance. Its aim is to allow innovative design without compromising safety.

3.7.2 The audit is a collection of assessments prepared by a professional team appointed by the developer. Specialists will consider a proposal in accordance with relevant guidance relating to their subject area. The grouping of assessments will then make it easier for the team to identify compromises in the design to be considered and rectified as necessary collaboratively. The design should be discussed openly and be agreed with the County Council at pre-application stage, planning submission, and during the section 38/278 technical approval process.

3.7.3 The content of the quality audit may vary between projects and the aim of the proposal. This should be made clear in a project brief that sets out the vision of the development. The quality audit should not be a tick box exercise but could simply be a sequence of checks to inform the design process depending on the scale of the development. A typical audit must address the following:

- a review of the function of the street
- a Road Safety Audit
- an inclusive access audit
- a walking audit
- a cycle audit
- a materials audit
- a parking audit; and
- maintenance audit.

3.7.4 The scope of the audit should be agreed with the County Council such that the decision making process delivers a balanced high quality development to the benefit of all its users.

### Design Stage

3.7.5 A quality audit report should be produced to summarise the steps undergone as part of the design process which should be updated through each level of approvals. It should highlight what considerations have been given to all key areas and provide an audit trail of the decision making process where compromises or departures from normal standards have been made.

3.7.6 For the quality audit to be fully understood, it should include the project brief and plans and particulars that detail the extent of the proposal.

### The Report

3.7.7 The quality audit report will be required to sum up under separate headings how the following is achieved:

#### Street Hierarchy:

- Places pedestrians first and is inclusive

- Integrates with surrounding networks
- Contains good connectivity for all modes and users
- Allows good navigation
- Configured to allow walkable access to amenities; and
- Is integrated with public transport

#### **Street Layout:**

- How reduced vehicle speed is encouraged
- How pedestrians are given priority
- How parking needs have been met flexibly
- How service and emergency vehicles are accommodated

#### **Detailed design:**

- How SUDS techniques are proposed and how they are to be managed
- How accommodation is provided for utility services
- How landscaping features are to be integrated into the proposal
- How a contextual, distinctive, durable and maintainable pallet of materials is to be used
- How street clutter is to be minimised

### **Summary of Additional Information as made necessary by the project:**

#### **Transport Assessment (TA)**

3.7.8 Sum up matters in the TA or Travel Plan that have influenced the street design

#### **Road Safety Audit**

3.7.9 Append audit and sum up safety issues

#### **Other Audits**

3.7.10 Append as necessary where they impact on overall quality of street design and summarise findings

#### **Accessibility and Equality**

3.7.11 Provide details of key features that ensure that the scheme will be functional for people with impaired mobility or other disabilities. Demonstrate that the scheme complies with the Equalities Act 2010.

### **Quality Audit Summary & Conclusion**

3.7.12 Summarise the decision-making process where conflicts have occurred between different areas of the audit and the proposed solution. Append a balanced risk assessment of the most significant risks and their likelihood and severity.

3.7.13 Conclude with a judgement of overall street quality.

### **Reference Documents**

The Design Manual for Roads and Bridges – GG119 Road Safety Audits

Equality Act 2010

Manual for Streets

Manual for Streets 2: Wider Application of the Principles



Local Transport Note 1/08

Traffic Advisory Leaflet 5/11

[End]



# Headroom, clearances, structures and obstacles on, in, and over the highway Part 3.8

## **Vertical clearance**

3.8.1 Where it is proposed to construct a bridge, building or gantry over the carriageway a minimum vertical clearance of 5.3m or 5.7m should be maintained over the full width of the street including footways, verges and any central reserves in accordance with Department for Transport Standard CD127.

3.8.2 The normal minimum vertical clearance of a projection over a footway or footpath should not be less than 2.6m increasing to 2.7m over a cycleway but not within 0.5m of a carriageway. When any projection over the highway is proposed in a pedestrianised street with service vehicle access or an emergency link, the vertical clearance should be increased to 5.3m above the walkway.

## **Horizontal clearance**

3.8.3 Buildings should generally be set back a minimum of 0.5m from the edge of highway boundary to allow private soil pipes, guttering, eaves, and opening windows etc. to project from the building but not encroach into the street.

3.8.4 Street furniture, signs, bollards, guardrail, above ground utility apparatus etc. should be a minimum distance of 450mm from the edge of carriageway.

## **Licence**

3.8.5 Section 177 of the Highways Act 1980 says it is an offence to construct a building, or alter a building such that it projects over an existing public highway without a licence being granted under that section by the County Council. Developers should be aware that it is also an offence under Section 153 of the Act for doors, windows and gates etc. to open into the public highway without prior consent from the County Council.

3.8.6 The County Council is unlikely to permit projections over the highway. Development that includes simple projections such as oriel windows, outward opening fire exits, externally mounted air con units, projecting signs, balconies, and canopies etc. should be suitably set back unless there are exceptional circumstances.

3.8.7 Should the County Council consider a proposed private structure appropriate to be covered by a licence whether in, over, or under a street, the terms of the licence will require the design of the structure to be approved, a structural inspection every two years, and public liability insurance.

## **Ramps**

3.8.8 A disabled ramp intended to access a building should be located inside if it cannot be fully accommodated beyond the limits of the street. Only in exceptional circumstances would the County Council consider a private ramp in the highway. The need for the ramp must be greater than the need for the walkway it was to occupy, sufficient walkway must remain such that the ramp would not create an obstruction or cause a bottleneck, and it must be demonstrated that no other solution is feasible. The cost of making alterations to a building is not a material consideration in this respect.

## **Pavement Cafés**

3.8.9 Pavement cafés may be permitted under S115E licence subject to certain conditions including the need to maintain a minimum clear footway width of 2.1m in town centres and 1.8m elsewhere

between the boundaries of the pavement café and any street furniture or carriageway. In a Pedestrianised area there must be at least 3.5m of unobstructed space in front of the pavement café so that large vehicles such as delivery lorries and fire appliances can pass. The pavement café shall not obscure sight lines for any highway user, interfere with drainage or conflict with pedestrian crossing points.

### **Bin Storage**

3.8.10 Where a single dwelling has the benefit of a driveway, it will not normally be necessary to provide a bin storage area.

3.8.11 Where a driveway or entrance is intended to provide access to multiple dwellings, a bin storage area will be required typically L75cm x D100cm per bin. This should take into account whether the bin store is a temporary location for collection days only or whether the bin store is intended to permanently house both general waste and recycling bins.

3.8.12 Purpose-built multiple-occupancy dwellings such as flats and student halls of residence should be provided with a communal waste storage and collection system using large containers housed in one or more enclosed bin storage area.

3.8.13 It will not normally be appropriate for developments to be reliant on bins being left on footways or within areas that would likely obstruct the visibility splays from adjacent accesses or junctions.

3.8.14 The collection point will nearly always be at the edge of the property where it meets the highway/footway.

[End]



# Residential Parking

## 4.1.1 Residential car parking standard

Where the district or borough council has not adopted its own parking standard, parking should be provided as follows:

**Table T4.1.1**

Dwelling Size (all dwelling types)	Allocated car parking spaces (minimum)
1 bedroom	≥1 space per dwelling
2 to 3 bedrooms	≥2 spaces per dwelling
4 or more bedrooms	≥3 spaces per dwelling

Where a lower level of parking provision is proposed this must be justified by calculating parking demand in accordance with DCLG *'Residential Car Parking Research (2007)'* or by local surveys.

The minimum parking requirements for retirement homes, sheltered accommodation, and extra care housing, shall be individually assessed within a Transport Statement or Transport Assessment to be submitted in support of a planning application. Houses in multiple occupancy (HMO) will be required to providing parking in accordance with the above table or local standard unless evidence is provided that demonstrates a lower parking provision is appropriate on a case by case basis.

Residential developments will not be supported should they be likely to result in excessive on street parking that would:

- impair road safety;
- obstruct access for vehicles, including for service vehicles, the emergency services and buses; and
- obstruct footways and be a hazard to cyclists and pedestrians, including those with mobility or visual impairments.

Garages may only be counted as parking spaces if they have the following internal dimensions. Car ports, which are unlikely to be used for storage purposes, may be counted as parking spaces provided these minimum dimensions are also achieved.

- Standard single = 6m x 3.0m, with minimum door width of 2.286m (7'6")
- Use by disabled = 6m x 3.3m with minimum door width of 2.286m
- Double = 6m x 6m, with minimum door width of 4.267m (14')

## 4.1.2 Driveway lengths

**Table T4.1.2**

Garage door type	Minimum distance from highway boundary
No garage	5.5m
Roller-shutter, sliding, or inward opening	5.5m

Up-and-over	6.1m
Hinged, outward opening	6.5m

### 4.1.3 Parking space widths

When designing off street parking spaces, it will be necessary to consider the space requirements of the user i.e. a parent getting a baby out of a car or installing a child's car seat, the elderly or mobility impaired, clearance to allow a wheelie bin or a bicycle passed a vehicle etc.

The minimum single driveway width is 3.0m or 3.6m when access is needed to both sides of the vehicle. A width of 3.6m is also appropriate if a driveway is located between two dwellings or other width restriction. A further 3.0m is required for a double width driveway with no physical separation between spaces and then a further 2.4m for each additional vehicle to be parked at 90 degrees to the carriageway side by side. Additional width may be required for disabled access. Typically, right angled spaces require a 6.0m minimum aisle width for reasonable manoeuvring.

For shared driveways see Part 3.1 General Geometry of Resident Streets. Additional width may be required to allow access by refuse vehicles and fire appliances to be defined by vehicle tracking should access be required within the site.

**Table T4.1.3**

Number of spaces	Minimum parallel parking space width	
	Open plan	Adjacent buildings, fences, and other physical boundaries
1 <sup>st</sup> space	≥3.0m	≥3.6m (≥3.3m if bound on one side only)
2 <sup>nd</sup> space	+3.0m	+3.0m (6.6m ÷ 2 = 3.3m each)
>2 spaces	+2.4m/space	+2.4m/space

### 4.1.4 Tandem parking

Where driveway lengths are extended to provide tandem parking, driveway lengths should be extended by 5.0m (a full car length) to avoid vehicles overhanging the highway and obstructing footways (see para. 4.1.5 Long driveways).

### 4.1.5 Long driveways

Long driveways intended to provide parking for multiple cars may only be counted as 2 spaces if vehicles would be blocked from exiting by other vehicles.

Manual for Streets suggests that residents should not be required to relocate bins more than 30m to a collection point and expects waste collection vehicles to be able to get to within 25m of a collection point. However, waste collection authorities may adopt their own standards. Most would expect bin storage areas to be directly accessible from the roadside. If this is not feasible, the local authority waste collection service should be consulted. Where a development is situated more than 45m from the highway, access may be required for a fire appliance in order to comply with Building Regulations.

Where a driveway exceeds 25m in length, adequate internal turning provision will be required for a van of up to 3.5 tonnes to avoid the need for the majority of deliveries to have to reverse long distances. A similar provision may be required on driveways of shorter lengths where it is not possible or appropriate to stop on-street.

#### 4.1.6 Communal parking areas

See Commercial Parking - Dimensions for car parking spaces

#### 4.1.7 Gates

Gates should never be hung to open outward over the highway, S153 Highways Act 1980. On classified roads, bus routes, and busy minor streets, gates will usually be set back 5.5m to allow a vehicle to clear the public highway.

#### 4.1.8 Cycle parking

Cycle parking shall be provided in accordance with the district or borough council's guidance. Where they do not have their own guidance, cycle parking shall be provided at a rate of 1 space per bedroom. Sheltered/elderly housing or nursing homes shall provide parking at a rate of 0.05 spaces per bedroom. Staff parking shall be provided at a rate of 1 space per 5 members of staff with a minimum of 1 space. Spaces must be secure and undercover in all instances.

#### 4.1.9 Mobility scooters and motorcycle parking

Mobility scooter parking is likely to be required within a residential development usually within garages or secure gardens. Where this cannot be accommodated, say within an apartment complex, separate provision will be required where scooters are able to be locked to an immovable stand with access to a charging facility at a rate of 1 space / 4 dwellings. This should include a shed structure to provide additional security if not within a building or communal garage space. Any parking area should be well positioned in terms of surveillance from residents, well lit, easily accessible, and able to accommodate mobility scooters up to 1.3m long x 0.85m wide with additional space for manoeuvring.

Similar provision will be required for motorcycle parking at a rate of 1 space / 10 dwellings. Parking spaces should normally be 2.5m x 1.5m with a 1m space between each bike. A secure ground anchor point is required for each space. It may be possible for the area to be shared with the mobility parking area.

#### 4.1.10 Residential turning heads

Normally to be provided on 'A' and 'B' class roads, high frequency bus routes, and other busy routes.

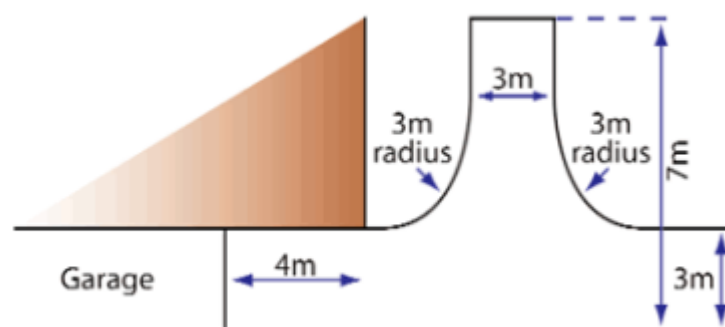

The area required for turning should not form part of the overall space required for parking. Driveway width subject to change, see Driveway widths above. Larger turning areas may be required if it is necessary to accommodate delivery vehicles.

#### 4.1.11 Surfacing and drainage

Driveways to be surfaced in a bound material (not loose gravel) within 5m of the highway and must be drained to prevent the unregulated discharge of surface water onto the highway. This is to prevent the transportation of gravel into the street which may present a hazard and to ensure that highway drainage remains capable of dealing with highway water only. Alternative permeable surfacing is likely to be acceptable subject to approval.

#### 4.1.12 Driveway approach

In a conventional layout driveways should be angled perpendicular to the carriageway. Only in exceptional circumstances would a driveway that is located at an acute angle be acceptable, for instance at the end of a cul-de-sac where there is ample space to manoeuvre in order to exit the street in a forward direction. Parallel parking immediately at the back of a footway is unlikely to be acceptable due to the potential conflict with pedestrians.

#### 4.1.13 Electric vehicle charging

**Table T4.1.4**

Residential Development	EV charging requirement	Charging point specification	Power requirement
Houses	1 fast charge socket per house	7kw Mode 3 with Type 2 Connector	230v AC 32 Amp single phase dedicated supply
Flats/Apartments	20% of spaces to be fitted with a fast charge socket plus 20% infrastructure only	7kw Mode 3 with Type 2 Connector plus feeder pillar or equivalent permitting future connection.	
C2 Care/Nursing Home			
C3 Elderly (Sheltered)			

Charging points should avoid the need for cables to span footways, paths, and vehicle routes

[End]



# Commercial Parking

## Part 4.2

**4.2.1** Where the district or borough council has not adopted its own parking standard, parking should be provided as follows:

**4.2.2 Normal minimum parking standards**

Use	Spaces / m <sup>2</sup> (GFA unless otherwise stated)	Minimum requirement
Food retail	One space / 14m <sup>2</sup> ≥100m <sup>2</sup>	Min 4 spaces / Unit
Non-food retail inc. financial and professional services	One space / 20m <sup>2</sup> ≥100m <sup>2</sup>	Min 4 spaces / Unit
Offices	Urban town* centre or edge of centre; One space / 60m <sup>2</sup>	Min 2 spaces / Unit
	Rest of Urban town*; One space / 35m <sup>2</sup>	
	Rural town centre or edge of centre; One space / 40m <sup>2</sup>	
	Rest of rural town; One space / 30m <sup>2</sup>	
	Out of any town; One space / 30m <sup>2</sup>	
Light and General industry	Urban town* centre or edge of centre; One space / 130m <sup>2</sup>	Min 2 spaces / Unit
	Rest of urban town*; One space / 80m <sup>2</sup>	
	Rural town centre or edge of centre; One space / 90m <sup>2</sup>	
	Rest of rural town; One space / 65m <sup>2</sup>	
	Out of any town; One space / 55m <sup>2</sup>	
Storage and Distribution	Urban town* centre or edge of centre; One space / 300m <sup>2</sup>	Min 2 spaces / Unit
	Rest of urban town*; One space / 180m <sup>2</sup>	
	Rural town centre or edge of centre; One space / 200m <sup>2</sup>	
	Rest of rural town; One space / 150m <sup>2</sup>	
	Out of any town; One space / 120m <sup>2</sup>	
Restaurants, cafés	1 space per 5m <sup>2</sup> of public area plus 1 space per 2 f/t equivalent staff	Min 2 spaces / Unit



	members	
Public houses, licensed clubs	1 space per 2.5m <sup>2</sup> of net bar area plus 1 space per 2 f/t equivalent staff members	Min 2 spaces / Unit
Pub restaurants	1 space per 10m <sup>2</sup>	Min 2 spaces / Unit
Take-away hot food shops (excluding fast food drive-thru restaurants)	1 space per 5m <sup>2</sup> of public area plus 1 space per 2 f/t equivalent staff members	Min 2 spaces / Unit
Food & Drink - Fast food drive-thru restaurants	1 space per 8m <sup>2</sup>	Min 2 spaces / Unit
Cinemas and conference facilities	One space / five seats	N/A
Assembly and Leisure excluding cinemas, conference facilities and stadia	One space / 22m <sup>2</sup>	N/A
Higher and further education	One space / two staff plus one space / 15 students	N/A
Stadia	One space / 15 seats	N/A

**\*Urban towns – Nottinghamshire**

Arnold, Beeston, Carlton, Hucknall, Stapleford, West Bridgford, Eastwood, Kimberley, Mansfield, Mansfield Woodhouse, Warsop, Sutton-in-Ashfield, Kirkby-in-Ashfield. Everywhere else should be considered to be a rural town.

**4.2.3 Departures from standard**

Where a lower level of parking provision is proposed this must be justified within a Transport Assessment or Statement. Commercial developments will not be supported should they be likely to result in excessive on street parking that would:

- impair road safety;
- obstruct access for vehicles, including for service vehicles, the emergency services and buses; and
- obstruct footways and be a hazard to cyclists and pedestrians, including those with mobility or visual impairments.

**4.2.4 Normal minimum disabled parking standard**

Car park use	Car park size	
	Over 4 spaces up to 200 spaces	Over 200 spaces
Employees and visitors to business premises	One bay or 5% of total parking spaces whichever is greater	Six bays plus 2% of total parking spaces
Shopping, recreation and leisure	Three bays or 6% of total parking spaces whichever is greater	Four bays plus 4% of total parking spaces

Schools and higher and further education	At least one bay regardless of car park size	At least one bay regardless of car park size
--	--	--

#### 4.2.5 Minimum servicing provision

Description of land use	Normal servicing provision
Shops	Stores above 5,000m <sup>2</sup> - One goods bay space / 1000m <sup>2</sup>
	Stores between 3000m <sup>2</sup> to 5000m <sup>2</sup> - One goods bay space / 750m <sup>2</sup> ;
	Stores between 300m <sup>2</sup> to 3000m <sup>2</sup> - You must make provision within the site for service and delivery vehicles to be loaded and unloaded clear of the highway.
Restaurants, cafes and drinking establishments	You must make provision within the site for service and delivery vehicles to be loaded and unloaded clear of the highway.
Light industry, Research and development	One lorry space for every 500m <sup>2</sup>
General industrial	One lorry space for every 400m <sup>2</sup>
Storage and distribution	One lorry space for every 400m <sup>2</sup>

All commercial premises must include adequate servicing provision regardless of scale. As well as complying with the above standards, the design of commercial premises should include access for the movement and parking of goods vehicles that are compatible with the Freight Transport Association publication '*Designing for Deliveries*'.

#### 4.2.6 Parking for motor cycles

The parking standard for motorcycles and mopeds is one space, plus an additional space for every 10 car parking spaces. Parking spaces should normally be 2.5m x 1.5m with a 1m space between each bike. A secure ground anchor point is required for each space.

#### 4.2.7 Minimum cycle parking provision

Use class	Sub-category	Short stay requirement (obvious, accessible, and close to destination)	Long stay requirement (secure and covered)
All	Parking for adapted cycles for disabled people	5% of total capacity co-located with disabled car parking	5% of total capacity co-located with disabled car parking.
Retail	Small (<200m <sup>2</sup> )	1 per 100m <sup>2</sup>	1 per 100m <sup>2</sup>
	Medium (200-1,000m <sup>2</sup> )	1 per 200m <sup>2</sup>	1 per 200m <sup>2</sup>
	>1,000m <sup>2</sup>	1 per 250m <sup>2</sup>	1 per 500m <sup>2</sup>
Employment	Office/Finance (A2/B1)	1 per 1000m <sup>2</sup>	1 per 200m <sup>2</sup>
	Industrial/Warehousing (B2/B8)	1 per 1000m <sup>2</sup>	1 per 500m <sup>2</sup>

Use class	Sub-category	Short stay requirement (obvious, accessible, and close to destination)	Long stay requirement (secure and covered)
Leisure and Institutions	Leisure centres, assembly halls, hospitals and healthcare	Greatest of: 1 per 50m <sup>2</sup> or 1 per 30 seats/capacity	1 per 5 employees
	Educational Institutions	-	Separate provision for staff and students based on Travel Plan mode share targets. Minimum: Staff: 1 per 20 staff Students: 1 per 10 students

#### 4.2.8 Electric vehicle charging

Commercial development	EV charging requirement	Charging point specification	Power requirement
Retail	Minimum of 1 space up to 25 spaces plus 10% of spaces thereafter to be fitted with a fast charge socket plus a further 10% infrastructure only	7kw Mode 3 with Type 2 Connector plus feeder pillar or equivalent permitting future connection.	230v AC 32 Amp single phase dedicated supply
Business	Minimum of 1 space up to 10 spaces plus 10% of spaces thereafter to be fitted with a fast charge socket plus a further 10% infrastructure only	7kw Mode 3 with Type 2 Connector plus feeder pillar or equivalent permitting future connection.	230v AC 32 Amp single phase dedicated supply
Assembly and Leisure	Minimum of 1 space up to 25 spaces plus 10% of spaces thereafter to be fitted with a fast charge socket plus a further 10% infrastructure only	7kw Mode 3 with Type 2 Connector plus feeder pillar or equivalent permitting future connection.	230v AC 32 Amp single phase dedicated supply
Sui generis use	To be individually assessed minimum of 1 space	7kw Mode 3 with Type 2 Connector plus feeder pillar or equivalent permitting future connection.	230v AC 32 Amp single phase dedicated supply

#### 4.2.9 Dimensions for car parking spaces

- Absolute minimum of 2.4m wide by 4.8m long.
- Desirable 2.5m wide by 5.0m long.
- End spaces require a minimum width of 3.3m where there is a physical boundary.

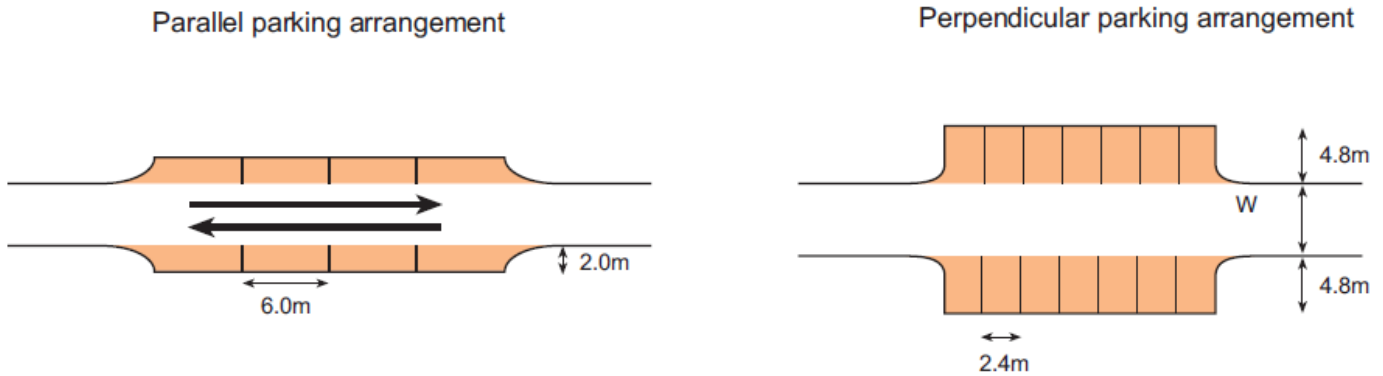

The width (W above) needed to access echelon or perpendicular spaces conveniently, depends on the width of the bay and the angle of approach. For a 2.4m wide bay, these values are typically:

- at 90 degrees, W = 6.0m;
- at 60 degrees, W = 4.2m; and
- at 45 degrees, W = 3.6m.

The width requirements can be reduced if the spaces are made wider. Swept-path analysis can be used to assess the effect of wider spaces on reducing the need for manoeuvring space, as illustrated in the diagrams below.

Tracking assessment

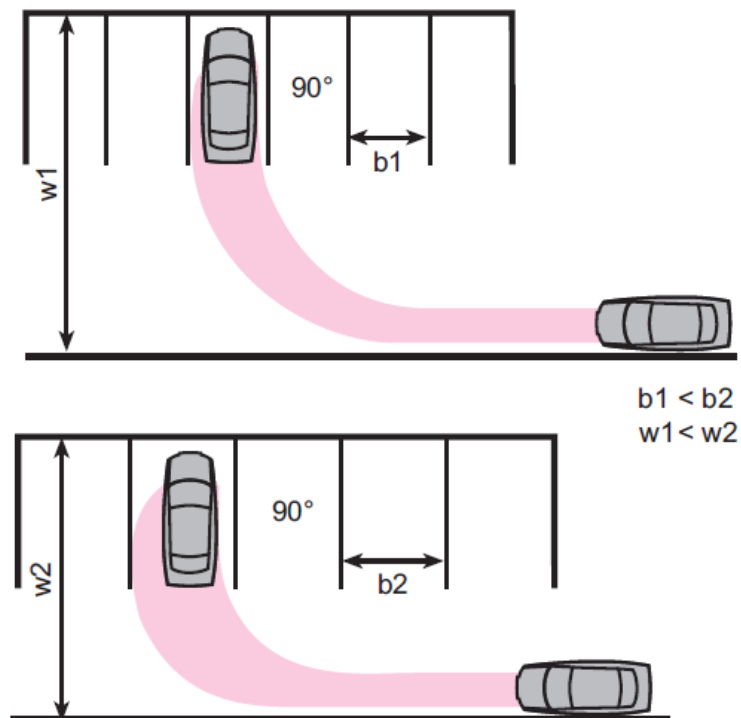

[End]

# Materials

## Part 5.1

### 5.1.1 Specification

All highway works must normally be in accordance with the 'Specification for Highway Works' published by Her Majesty's Stationery Office as Volume 1 of the Manual of Contract Documents for Highway Works (MCHW) and comply with the 'Notes for Guidance on the Specification for Highway Works' published as Volume 2, 'Sewers for Adoption' published by WRc plc where stated, as well as our specification and standard drawings. Where these vary from the 'Specification for Highway Works' our documents should prevail. If your proposals are not covered by the standard drawings, you will need to submit scheme-specific drawings to us for approval.

### 5.1.2 Site surveys, tests and investigations

You must arrange any site surveys, tests and investigations that we need before you submit your design to us. These must cover:

- a land survey including features such as watercourses, ditches, existing drainage systems and outfalls; and services and existing foundations;
- a survey of existing trees and other soft landscape features including the condition of each tree, its size and form and details of tree preservation orders and so on;
- nature-conservation surveys;
- details of how surface water run-off will be dispersed;
- consultation with the Environment Agency, Internal Drainage Board, and Lead Local Flood Authority as appropriate;
- the depth of the water table and perched water tables;
- the impact on adjacent developments and land;
- a risk assessment of chemical contamination;
- the presence of hazardous materials;
- the stability and acceptability of earthworks;
- an assessment of subgrade strength;
- the frost susceptibility of subgrade;
- the suitability of subgrade soils for lime or cement stabilisation (if required); and
- the possible recycling of on-site materials.

### 5.1.3 Sampling and testing goods and materials

You must arrange and pay for all the sampling and testing outlined in our Specification. You must also submit one copy of these test results to our Engineer. Our Engineer reserves the right to carry out any sampling and testing deemed necessary to confirm that the goods and materials meet with the Specification including core samples. If we find the work does not meet the Specification, you will be required to pay for the associated costs to the authority. A list of the likely samples of goods and materials required can be found in the Specification.

#### **5.1.4 Marking the highway boundary**

It is important that there is clear demarcation between public and private space. You must define the highway boundary by continuous 50mm x 150mm edging type EF to BS7263 unless we agree otherwise.

#### **5.1.5 Fencing and barriers**

We will not adopt any fencing erected on the highway boundary unless it is provided as a safety feature at the top of any highway structure, or is a safety or noise barrier. A commuted sum would likely apply in all instances.

Safety fences and barriers must comply with Section 2 of 'Highway Construction Details' published by Her Majesty's Stationery Office as Volume 3 of the Highways Agency's Manual of Contract Documents for Highway Works. Safety Fencing should not generally be included within residential developments.

#### **5.1.6 Existing boundaries**

You must make it clear to purchasers of individual property at the time of sale that you are transferring ownership and responsibility for existing highway boundaries to them. The lack of maintenance and cutting back of hedges is a common problem for us, particularly where the hedge had enclosed farmland or had not been regularly maintained previously. If you erect new fencing to the inside of existing hedges and fences the purchaser may mistakenly believe that the original hedge or fence is our responsibility. Access to hedges should be available to both sides for maintenance.

#### **5.1.7 Pedestrian barriers**

It may sometimes be necessary to introduce barriers to pedestrian movement. Where they are required, consideration should first be given to amending the layout or the use of features that can guide pedestrian movement whilst also contributing to the amenity of the street.

#### **5.1.8 Pedestrian guardrails**

Where it is not possible to avoid the use of barriers by design and where using a staggered barrier is not appropriate at the ends of footpaths, you must provide an agreed length of pedestrian guardrail which runs parallel to the edge of the street, leaving a clearance of 450mm from the carriageway. You may need to widen the footway to maintain the standard footway width past the guardrail. You must use guardrails where the number of pedestrians makes it necessary for you to channel them to the appropriate crossing point. You should take care to make sure that the guardrails do not interrupt visibility. You should normally use high visibility pedestrian guardrail.

#### **5.1.9 Noise fencing**

Unless we agree otherwise, noise fencing should be subject to a private maintenance agreement. However, it must meet the design requirements for a highway structure. Where it is necessary to adopt as a highway structure, you must pay us design checking fees and a commuted sum for its future maintenance.

#### **5.1.10 Earthworks**

All earthworks must comply with Series 600 (MCHW) and Appendices 6/1, 6/2, 6/7 and 6/8 of our Specification. Embankments and other areas of fill must be formed of acceptable material excavated from within the site or imported on to the site, meet the requirements of Appendix 6/1 of

our Specification for use in the permanent works, and have the approval of our Engineer to be used in that particular location.

## Street pavements

### 5.1.11 Constructing the site access and roads external to a development

The design and construction of works on classified roads and other roads (existing or proposed) not covered by this design guide must normally comply with the 'Design Manual for Roads and Bridges' published by Her Majesty's Stationary Office.

### 5.1.12 Internal development streets

Listed below are the street types covered by this design guide. The construction varies according to the street type. It is essential that you mark the street category clearly on the plans you submit for approval in line with the abbreviations in the table.

**Table T5.1.1**

Street & Road category	Abbreviation
Residential Street	RS
Residential access way	RAW
Major industrial access road	MajIAR
Minor industrial access road	MinIAR

### 5.1.13 Subgrade assessment

For design purposes, you must establish the CBR before you begin construction. You should notify us in advance of site tests to establish the subgrade strength and give us the opportunity to be present at such tests. You should provide the County Council with copies of all test results.

You should use soil-classification tests to give the types of soil and 'Equilibrium CBR' based on material type, using the table below unless we agree otherwise. That is the soil strength when the material is neither gaining or losing moisture (equilibrium moisture content (EMC)).

**Table T5.1.2**

Type of soil	Plasticity index	Equilibrium CBR%
Heavy clay	50 or greater	Less than 2
Heavy clay	40 to 49	2
Heavy clay	30 to 39	2
Silty clay	20 to 29	3
Sandy clay	10 to 19	4
Silt	Less than 10	1
Sand (poorly graded)	Non-plastic	20
Sand (well graded)	Non-plastic	40
Gravel (poorly graded)	Non-plastic	40

Sandy gravel (well graded)	Non-plastic	60
----------------------------	-------------	----

### 5.1.14 Carriageway sub-base and capping layer

**Table T5.1.3**

Use the table below to find the thickness of capping and sub-base you need to use.

CBR Value	Materials within 450mm of surface must not be frost susceptible					
	Residential Street (250mm Bituminous layer thickness)		Residential Access Way (200mm Bituminous layer thickness)		Industrial Road (300mm Bituminous layer thickness)	
	Capping	Sub Base	Capping	Sub Base	Capping	Sub Base
< 2%	550	200	500	250	600	150
2%	400	200	350	250	450	150
3%	300	200	250	250	350	150
4%	250	200	200	250	300	150
5% to 15%	200	200	200	250	250	150
> 15%		200		250		150

The foundation design should not vary frequently along the street. You should select an appropriate value for each significant change in the subgrade properties. Where the equilibrium CBR falls between values in the above table, you should round down the value to the lower value. When the subgrade CBR is sufficiently below 2% that capping with sub-base is not sufficient to support the pavement, special measures will be required to be approved by the County Council. Note that the use of geo-textile will only be acceptable in certain situations. You can find advice in DMRB IAN 73/06 Rev 1.

### 5.1.15 Capping materials

You will need approval for each site for the capping layer which must comply with our specification Table 6/1, Type 6F2 or 6F3. You must test the capping layer as necessary to demonstrate that it has an in-situ CBR of 15% (or equivalent test result). We may approve other materials as long as you have previously demonstrated to us that they will achieve an in-situ CBR of 15% (or equivalent test results).

### 5.1.16 Sub-base

Sub-base must be Type 1 to Series 800 MCHW, Clause 803.

### 5.1.17 Surface, binder courses and bases

The table below gives the required minimum design thicknesses and options you have for the flexible and modular (block) materials you should normally use for different development street types.



**Table T5.1.4**

**Road carriageway construction materials depth**

	Residential street			Residential access way and shared surfaces				Industrial access road			
	Bituminous		Block	Bituminous		Block	Bituminous				
			Notes		Notes			Notes			
Surface course	40mm	SMA 10 surf 40/60 (PSV 55)	1.2	80mm	40mm	SMA 10 surf 40/60 (PSV55)	1.2	80mm	50mm	HRA 35/14 F surf 40/60 des (20mm pre-coats)	1
	40mm	HRA 55/10 Type F surf 40/60 des	2		40mm	HRA 55/10 F surf 40/60 des	2				
	40mm	AC 10 Close surf 100/150	2		40mm	AC 20 dense bin 100/150 rec	2				
Binder course	60mm	AC 20 dense bin 100/150 des		30mm sand 60mm AC20 dense bin 100/150 rec	60mm	AC20 dense bin 100/150 rec		30mm sand 110mm AC20 dense bin 40/60 rec	60mm	AC20 dense bin 40/60 rec	
									60mm	AC20 HDM bin 40/60 des	
Base	150mm	AC32 base 40/60 rec		100mm AC32 base 40/60 rec	110mm	AC32 base 40/60 rec			190mm	AC32 base 40/60 rec	3
									190mm	AC32 HDM base 40/60 des	3
1	Polished stone value (PSV) of course aggregate in surfacing course shall be determined from table of investigatory levels, see DMRB Part 1 HD36/06 but not less than 55										
2	HRA 50/10 bin 40/60 (material ref REG1) may be used for hand laying speed tables										
3	Subgrade assessment for capping layer and sub-base design are covered above										
4	Any binder course material laid as a running surface prior to the final surface course being laid must have a minimum PSV of 55 and an AAV (aggregate abrasion value) of 7. This includes under block paved surfaces in carriageways										

Higher category roads not covered by the above table should be designed on a site-by-site basis to Design Manual for Roads and Bridges, Volume 7. Where it is necessary to alter or improve an existing road to serve a development, in most cases the minimum depth of surface course, binder course and base layer should normally not be less than that of the site access road unless otherwise agreed. For example, if you are widening a road to serve a housing development accessed by a 'residential street', then the material depth should not be less than 250mm - equal to 40mm+60mm+150mm. It may be necessary to overlay the existing carriageway to achieve the required depth.

We will not usually accept the use of block-paving for industrial roads.

#### **5.1.18 Concrete-block paving**

Where we agree that it is appropriate, you may lay concrete-block paving to carriageways, shared surfaces and other areas used by vehicles. The blocks should be laid instead of a bituminous surface course to the standard thickness and material specification including the sub-base and base layers for the street type in question. Note that a binder course will be required as per above table. Commuted sums may be payable.

#### **5.1.19 High Friction Surfacing**

You are required to provide high friction surfacing on the approaches to signal controlled junctions, roundabouts and pedestrian crossings unless we agree otherwise. This will be either hot applied (thermoplastic) or cold applied (thermosetting) and must be in accordance with our Specification.

High friction surfacing must be applied for a minimum length of 50m ahead of the stop line on streets subject to a 30mph limit, but an increased length may be required due to the approach speed, accident record, average queue length, proximity of side streets and mix of traffic. Outside 30mph limits you should provide a minimum length equal to the stopping distance for the approach speed plus 10 m. On approaches to pedestrian crossings the high friction surfacing must be continued past the stop-line to the first line of crossing studs.

#### **5.1.20 Coloured Surfacing**

This will be either hot applied (thermoplastic) or cold applied (thermosetting) and must be in accordance with our Specification. We will require the payment of commuted sums to cover the future maintenance of such surfacing.

#### **5.1.21 Alternative materials for footways, cycleways, carriageways, and shared surface areas**

Where for aesthetic, environmental, or other such reasons you propose to use an alternative surfacing material, we will be prepared to consider its use so long as we have agreed its use at an early stage, the material meets the requirements of quality, durability, maintainability and sustainability, and in the interest of highway safety the material must meet specification requirements. To ensure that the surface can be kept safe and durable, we will need you to pay a commuted sum to cover the excess maintenance costs of most alternative materials and surfaces.

#### **5.1.22 Resurfacing carriageways at junctions with existing roads and widening existing roads**

Where a new carriageway meets an existing county road or an existing county road is widened and the construction joint falls within the running lane of the existing county road or involves any changes to the county-road carriageway, including additional areas of carriageway, you must overlay or resurface the whole of the altered or widened carriageway unless we agree otherwise. At

junctions, you must carry this out over the length from tangent point to tangent point of the junction radii. However, if the junction includes acceleration and deceleration lanes on the main carriageway, the full overlay or resurfacing of the whole carriageway must also include the full length of the lanes, unless we agree otherwise.

### 5.1.23 Kerbs, footways, footpaths, cycleways and other similar paved areas

The construction should be in line with the two tables below. You should also refer to the standard drawings and our Specification.

**Table T5.1.5**

<b>Residential Footways – construction materials and depths</b>				
	<b>Bituminous</b>		<b>Block Paving</b>	
Surface Course	25mm	AC6 dense surf 100/150	90mm	60mm blocks on 30mm bedding sand (compacted)
Binder Course	90mm	AC20 dense bin 160/220 rec	90mm	AC dense bin 160/220 rec
Sub-base	225mm (see note below)	Granular Type 1	225mm (see note below)	Granular Type 1

Note: The sub-base thickness is to increase to 270mm if likely to be parked on or over-run by lorries and to 365mm if CBR values are 2% or less.

**Table T5.1.6**

<b>Footway construction at vehicular accesses serving greater than 5 dwellings</b>			
		Access serving less than 25 dwellings	Access serving more than 25 dwellings
Bituminous	Surface course CGM	30mm	40mm
	Binder course DBM	85mm	60mm
	Base DBM	-	150
	Sub-base & Capping	270mm Type 1 GSB (see note above)	See CBR table
Block Paving	Blockwork	60mm	80mm
	Bedding sand (compacted)	30mm	30mm
	Base DBM	90mm	150mm
	Sub-base & Capping	270 Type 1 GSB	See CBR table

### 5.1.24 Concrete-block paving

Where we agree that it is appropriate, you may lay concrete-block paving to footways and other paved areas. The concrete block paving must comply with and be laid in line with the requirements of our specification for concrete-block paving in footways. If you use block paving you may need to pay a commuted sum.

#### **5.1.25 Pedestrian deterrent paving**

You may use approved pedestrian-deterrent paving in areas where pedestrians are to be discouraged.

#### **5.1.26 Footways and other hard-paved areas on industrial access roads**

The construction should be in line with the below table. Where a footway crossing is to be used to access an employment or commercial development, the footway crossing must be constructed in line with industrial access road requirements.

**Table T5.1.7**

<b>Footway and paved areas on industrial access roads - construction</b>		
	Bituminous	
Surfacing	40mm	HRA 55/10 F surf 100/150 des
Binder course	75mm	AC20 dense bin 160/220 rec
Sub-base	270mm increasing to 365mm for CBR values of 2% or less	Granular Type

Where there is a likelihood of regular parking on hard-paved areas or areas that would otherwise be grassed, you should use high-relief contour paving to deter vehicles.

#### **5.1.27 Flush dropped pedestrian and cyclist crossing points**

You must provide these at all points where pedestrians and cyclists cross or join a carriageway (including any access more than a simple vehicular footway crossing). These crossing points will normally be constructed to our standard drawing.

#### **5.1.28 Tactile paving surfaces**

You should construct tactile paving surfaces at all controlled and uncontrolled crossing points in accordance with the government publication 'Guidance on the use of Tactile Paving Surfaces' and our standard drawings.

#### **5.1.29 Widening existing footways, footpaths and cycleways**

You must overlay or resurface full width any existing footway, footpath or cycleway that is widened, unless we agree otherwise.

#### **5.1.30 Traffic signs, road markings, studs and traffic signals**

All traffic signs you use (including bollards, retro-reflecting road studs and road markings), whether permanent or temporary, must be the size, shape, colour and type prescribed in the Traffic Signs Regulations and General Directions, and the Zebra, Pelican and Puffin Pedestrian Crossings Regulations and General Directions.

#### **5.1.31 Traffic signs**

You must show the details of individual traffic signs, including their posts and foundations to our standard drawings and specification including the making out of traffic sign schedule sheets.

#### **5.1.32 Traffic Regulation Orders**

Traffic regulation orders are required for cycleways and may be required for footpaths, to stop motor vehicles or cyclists using them. They may also be required for certain traffic signs and road markings. The successful making of an order is not guaranteed. But, you must pay any costs we incur in making these orders or alterations to existing orders, whether or not the order is successfully made.

Before we make a TRO we have to carry out a public consultation. This gives members of the public the opportunity to raise objections. Because of this, the time it takes to complete the process can vary. You must pay any costs we incur carrying out these consultations whether or not the making of an order is successful.

#### **5.1.33 Changes to original road layout**

You must provide signs warning of a new road layout in accordance with the Traffic Signs Regulations and General Directions on all approaches to all permanent alteration to the original road layout as soon as it is brought into use. You must maintain these signs for three months and remove them at the end of that time.

#### **5.1.34 The electricity supply to illuminated traffic signs**

Most illuminated signs are to be fed by an electricity company supply. However, certain signs must be fed by a County Council private supply, for example, a bollard on a traffic island in the middle of the road.

Your layout plan must show the location of all signs and bollards that need illumination so that we can identify the requirements for the electrical supply. These will require incorporating into the street-lighting design.

You are responsible for arranging for the electricity company to provide the electricity supply to the illuminated signs or arranging for a County Council private supply, providing test certificates in accordance with British Standards and paying for all aspects of the works including paying energy charges and maintenance of the illuminated signs before we issue the final certificate.

#### **5.1.35 Bulk clean and lamp change' charges**

Before we issue the final certificate of completion, you must undertake or meet the cost of a 'bulk clean and lamp change' for street lighting, illuminated signs and bollards if more than 3 years have elapsed since installation. .

#### **5.1.36 Road markings**

You must provide road markings in accordance with the Traffic Signs Manual and the Traffic Signs Regulations and General Directions. You must show the location, colour and type of permanent road markings on your drawings which must comply with our Specification.

#### **5.1.37 Road studs**

You must provide road studs in accordance with the Traffic Signs Manual, show the locations and positions of road studs on your drawings. These shall be cored and filled with white thermoplastic at

pedestrian, cyclist and equestrian crossings to form marks as shown in the Traffic Signs Regulations and General Directions.

#### **5.1.38 Street name plates**

You are required to apply to the district council as the street-naming authority for names to be given to any new lengths of road. The district council will specify the details that they require, and you may be able to submit suggested names for consideration. The district council will advise you of the names chosen, following the necessary consultations. It is your responsibility to arrange the erection of the street name plates which the district council has chosen. Any street name plates on private drives or unadopted 'roads' should clearly state that the road or drive is 'private' or 'unadopted'.

#### **5.1.39 Traffic signal equipment**

We will normally design the traffic signals within the highway works based on detailed road layout drawings you have supplied. We will normally supply and install all permanent traffic-control equipment to be installed as part of the highway works. You must pay the reasonable cost to us for designing, supplying and installing the equipment including a commuted sum towards the future maintenance of the traffic-signal equipment. You must allow us access at all reasonable times to any part of the site on which cables, pipes, ducts or other apparatus associated with the traffic-signal equipment is to be installed or is located so we can carry out any works we need to do to install and maintain the cables, pipes ducts or other apparatus.

#### **5.1.40 Street lighting**

The street lighting design will require technical approval as part of a Section 38 or Section S278 designed submission unless undertaken by us as well amendments or removal of existing street lighting. This shall be produced in accordance with the British Standard and Manual of Contract Documents for Highways Works. Ducts to be adopted by the County Council should be orange, have a nominal internal diameter of 100mm, and be solid. You should contact the Electricity Distribution Network Operator to determine their requirements.

You are responsible for ensuring that the street lighting design is undertaken, ensuring that the specification of equipment is in accordance with our specification, marking the exact position of the street lights on site for the street lighting contractor, arranging for the electricity company to provide the electricity supply to the street lights, providing up to date test certificates in accordance with the British Standard, and paying for all aspects of the works including paying energy charges and maintenance of the street lights before we issue the final certificate of completion.

#### **5.1.41 Alternative street lighting**

The street lighting specification we provide will use 'standard' galvanised steel columns with road-lighting lanterns of the appropriate height and luminance. The use of heritage or other non-standard street lighting columns and lanterns will require our approval at an early stage and will attract a commuted sum to cover the increased costs of maintenance and replacement associated with this type of equipment.

Street lights may be mounted on buildings provided the necessary wayleave is secured for the lifetime of the development at no cost to the Council. In many settings, this may offer a better solution than providing columns and reduce street clutter.

#### **5.1.42 Street furniture and street art**

It is important to establish at an early stage (and certainly before any-planning application) what street furniture and so on is proposed within areas that are intended to be adopted as publicly-maintained highway, and who would be responsible for it. You may need to include this as part of a concept proposal that you are required to prepare for your proposed development. Details will be required as to who is to accept future maintenance responsibility. A commuted sum is likely to be payable for any assets not essential for highway purposes but to be maintained by us. The County Council does not adopt public art.

#### **5.1.43 Landscaping**

Streets, footways, footpaths, cycleways, grass, shrubs, and trees should complement the appearance of the development and the character of the surrounding area. The appropriate use of a variety of soft and hard landscaping materials, and the incorporation of existing trees and other features should be an integral part of the initial design.

Developers need to recognise that planted areas for adoption should be designed for minimal maintenance and may not be considered appropriate for highway purposes. Therefore the overall use of materials, planting and landscaping of any new development should be discussed at an early stage with the local planning authority and us. However, it is important for developers to appreciate that the issue of planning consent does not imply that all proposed landscaping will be accepted for adoption by the County Council.

In residential and industrial areas environmental features such as planting boxes, public open spaces, grassed areas, existing trees, hedges and fences and landscaped areas will not normally be adopted by the County Council. Where such features are proposed, the developer must agree with the local planning authority future maintenance arrangements.

#### **5.1.44 Hard Landscaping**

It may be preferable to use hard landscaping rather than grass or ground cover planting in small areas of verge and within visibility splays particularly if this is more appropriate for example in an urban setting.

#### **5.1.45 Grass**

Grass is the normal acceptable treatment for service strips, verges, and rural visibility splays either by way of grass seeding or the laying of turf in accordance with our specification.

The use of verges between carriageways and footways will require careful consideration as grass at the side of a road can make it difficult for some people to alight from cars, restricts pedestrian crossing movements, can become rutted due to on street parking, and can obstruct sight lines from junctions and accesses particularly when trees are incorporated within the verge. If verges are proposed, these may be located at the back of footways where they may cause issues if located at the edge of the carriageway and then can be maintained either by the frontages or by a management company. When highway adoption is considered appropriate, the County Council is likely to seek a commuted sum for future maintenance.

#### **5.1.46 Trees**

Trees on or next to the highway can be severely damaged by construction and maintenance work to streets and footways. Wherever possible, our policy is to retain, preserve and protect existing healthy highway trees when carrying out street construction. Protection measures must always be

thorough. You should put them in place before the works begin and maintain them until the works are finished.

Tree roots need to absorb oxygen to survive, so most of a tree's root system is found in the aerobic (oxygen-rich) soil within the 600mm immediately below the surface. The tree's roots absorb nutrients and moisture from the soil and can extend well beyond the area taken up by its crown.

Highway construction and maintenance design should allow for all healthy existing trees and where appropriate, the planting of new trees. You should involve our forestry officer or your consultant arboriculturalist who should advise at the planning and design stage on retaining existing trees and planting new specimens. You should consider the potential growth of retained trees, their future compatibility with new and existing highway features and how near new and existing service runs will be. You should identify an appropriate protection zone around the trees you are retaining and, wherever possible, you should exclude this area from the construction site. All necessary tree maintenance work, both before and after construction, should be carried out by trained operatives in consultation with our forestry officer.

We will adopt trees that have been successfully retained or have been planted in verges and other highway related land. We will not adopt any tree retained within a development if we know that it has been damaged by poor practices during construction and the appropriate protection measures have not been employed.

Trees should avoid sight lines from junctions and accesses and all new trees to be located in the highway should be within tree pits.

#### **5.1.47 Bird nesting season**

You must not remove or carry out work to existing or planted trees, shrubs, hedges and other vegetation during the bird nesting season. This is generally considered to be from March until the end of July but can cover a longer period. You should check for the presence of active nests outside that period.

[End]





# Drainage

## Part 5.2

### 5.2.1 Highway Drainage

We will ensure that developments that include streets to be adopted as highway provide satisfactory adoptable highway drainage arrangements. This should normally be achieved by one of the following methods:

- All highway water should be drained direct into a piped system vested or to be vested to a water company. This is the method we prefer.
- If the above method is not possible, water should be drained by a piped highway drainage system (minimum pipe size 225mm) running to a public sewer vested in a water company or outfall to a ditch or watercourse agreed by the Lead Local Flood Authority (LLFA), Environment Agency (EA), or Internal Drainage Board (IDB) as appropriate and supported by written evidence accordingly. We will normally insist that the street drainage system is adopted where we are adopting the street.

### 5.2.2 Easements

All highway drains should be located within land that we are adopting. Only in exceptional circumstances will we permit them in land that is to remain private. You must cover any adoptable highway drain outside the limits of the adoptable highway by an easement. The land must be easily accessible and not be in areas that would cause an unreasonable level of disturbance during maintenance such as private gardens or private driveways.

We will not adopt a street unless its associated drainage is to be adopted either by a water company or by us.

### 5.2.3 Alternative drainage systems and SUDS

We may consider alternative highway-drainage systems, including infiltration systems, flow attenuation (reduction) or retention systems (including oversized pipes) and so on, on a site-by-site basis provided this would not present us with a significantly increased maintenance liability when compared to a piped system.

Where SUDS techniques are to be deployed, we will require additional measures to ensure the system can be cleaned easily, accessed for maintenance purposes, and can be drained down in the event of a blockage or failure. Such measures may include upstream desilting measures, drain down measures such as penstocks and an emergency overflow to a sewer or other suitable discharge point.

In order to minimise the risk of failure, SUDS features should be distributed across the site. The use of a single feature as an outfall for the entire highway drainage system at the lowest point of the site will not generally be accepted.

All alternative drainage systems will be subject to a commuted sum payment.

## 5.2.4 Infiltration Systems

Provided there is no reasonable prospect of securing a positive drainage system in the manner described above to be demonstrated by evidence, infiltration may be considered in appropriate ground conditions. That is where adjacent soils have an infiltration rate greater than 10mm/hr and subject to the payment of a commuted sum and where the soakaway can be located at least 1.0m above the highest recorded groundwater level considering seasonal variances.

Infiltration systems must be located outside of the carriageway. Where this is not possible, and only in exceptional circumstances, their location must not prevent or severely restrict passage during maintenance. Structural calculations may be required to show that anticipated loading on the system can be tolerated without detriment.

Infiltration systems should be located a minimum of 5m from buildings. Where they are proposed to be located outside of the highway, they should comply with the easement requirements above. Easements may also be required to ensure that no building is subsequently located within 5m of an existing infiltration system such that the dispersal of water would not impair the stability of the structure.

Infiltration system locations must be considered at planning application stage to ensure there is enough space.

The design and installation of soakaways should be in accordance with Building Research Establishment (BRE) Digest 365 'Soakaway Design' and Construction Industry Research & Information Association (CIRIA) Report 156 'Infiltration Drainage – Manual of Good Practice'. We will require any application for adoption to be accompanied by completed Infiltration assessment which can be found at Appendix B.

Where you are proposing SUDS, you must hold discussions with all relevant parties at an early stage (and certainly before any planning application) to agree ownership and responsibility for the facility.

## 5.2.6 Private Drainage

We will not accept the drainage of non-adopted assets into a highway drainage system either adopted or to be adopted by us. In general, the drainage of most other areas of a development are matters for water companies. You should normally design these drainage systems in line with the water companies' specifications and requirements (which you may treat as complementary to this document) and they should be adopted by them.

Where necessary private development should provide cut-off drainage often in the form of linear drains or ditches to prevent the unregulated discharge of surface water onto adjacent streets.

## 5.2.7 Outfall design

Where a piped system discharges into an existing ditch or watercourse, the pipe invert (bottom of the inside of the pipe) must not be lower than the level of the base flow in the ditch or watercourse and it should always be at least 150mm above the ditch or watercourse invert. You must direct the end of the pipe so it discharges at an angle less than 60 degrees to the direction of flow in the ditch or watercourse. The end of the pipe must have a headwall and apron which supports the bank above and adjacent to the pipe and prevents any scouring underneath the pipe. You must protect the banks of the ditch or watercourse from scouring, and you must meet any requirements laid down by the LLFA, EA, and IDB.

If the outfall is to an existing highway drain, you will have to prove its capacity and condition before we can approve the connection. For all works incorporating highway drainage you will need to carry out and provide a copy of a CCTV survey and report. You must carry out any improvement works found necessary, all at your expense.

### **5.2.8 Existing drainage systems**

You must deal with any existing drainage systems within the development site, including any land drains, ditches, watercourses, outfalls or drainage systems from adjacent land, to our satisfaction and that of the LLFA, EA, and IDB as appropriate and the owners of the systems.

You must have consent to pipe an existing ditch or watercourse, in accordance with Section 23 of the Land Drainage Act 1991.

The discharge of adopted highway drainage to privately maintained drainage systems will not be accepted.

### **5.2.9 The hydraulic design of adoptable highway drains**

The hydraulic design of adoptable piped highway drains must meet the requirements of the current edition of 'Sewers for Adoption' published by WRc plc.

You must submit calculations using the specified method of calculation and format. We will accept output from an approved computer programme using the specified method and parameters.

### **5.2.10 Hydraulic design – protection against flooding**

The system must be designed to meet the requirements of the current edition of 'Sewers for Adoption' published by WRc plc.

The system should be designed not to flood any part of the highway or site in a 1 in 30 year return period design storm or any other return period that is set out in any latest version of 'Sewers for Adoption'.

Your design should also show the line and extent of flow paths and the potential effects of flooding if storms are greater than those allowed for by your design.

### **5.2.11 Minimum pipe size**

The minimum pipe diameter for adoptable highway drains, other than gully connections, is 225mm. The minimum size for a road gully connection is 150mm.

### **5.2.12 Use of combined kerb and drainage systems**

You must consider a combined kerb and drainage system where the minimum longitudinal carriageway gradient is less than 1 in 100 for flexible surfaces and less than 1 in 80 for block paved surfaces. We will normally require you to pay a commuted sum to cover any additional maintenance where a combined drainage system is used.

### **5.2.13 Approving drainage structures**

Any drain, pipe or box culvert, sewer or drainage structure that has a clear span or internal diameter of greater than 900mm or any headwall greater than 1.5m retained height, will be classified as a highway structure and be subject to the specific requirements that apply to highway structures.

### **5.2.14 Catchpits**

Unless otherwise specified, you must use catchpits and not manholes on adoptable highway drainage systems. Soakaway structures (typically over-sized chambers and cover slabs which are greater than 1050mm in diameter), even if they are to be adopted by the relevant water company, must still be designed to the relevant standards for retention within the highway (BS EN 1991-2:2003)

Eurocode 1: Actions on structures - Part 2: traffic loads on bridges). You will need to demonstrate to us that this has been achieved.

You must provide a catchpit (an access chamber, with sump, on a drainage system) where there is any discharge into an existing ditch or watercourse.

On all drainage runs we are to adopt where the pipe diameter is 900mm or less, you must provide a catchpit at:

- every change of alignment or gradient;
- the head of all main pipelines;
- every junction of pipelines except for single-gulley connections;
- every change in pipe diameter; and
- a maximum spacing of 90 metres.

### 5.2.15 Catchpit and manhole positions

You should normally locate catchpits or manholes within the verge, and not the carriageway, on classified roads and other roads with a higher status than a residential street or industrial access road. The outside of catchpits and manholes should be at least 500mm from the kerb line or the edge of the carriageway. Any catchpits or manholes within a carriageway must be located so that they can be accessed while providing the necessary safety zones and without preventing traffic from passing. This will generally mean that you should not site them at or near the centre of the carriageway or within a width restriction. You should also take care when locating catchpits or manholes within junctions or roundabouts, based on the same criteria.

### 5.2.16 Positioning and alignment of highway drains and storm and foul sewers

Highway drains must be laid:

- in straight lengths;
- to straight grades between catchpits; and
- within the carriageway or verge.

You must not lay drains and sewers and their associated catchpits or manholes in footways as this space is required for other utility apparatus.

### 5.2.17 Gullies

All gullies should be trapped and the maximum length of gulley connection should not be more than 15m. It will not normally be acceptable to connect one gulley connection directly into another. Gully spacing should be calculated from below table and accompanying notes:

**Table T5.2.1**

Carriageway Gradient	1/100	1/80	1/60	≥1/40
Area drained including footways etc.(m <sup>2</sup> ) assuming 1/40 crossfall	44 (126)	49 (141)	56 (162)	68 (196)
	The figures in brackets are appropriate for rural areas only. That is country lanes with no frontage development or footways.			

- When calculating the areas drained, you must make allowance for all footways, footpaths, paved areas and verges that fall towards the carriageway;
- Flow width of 0.5m and 0.75m are appropriate in built up and rural areas respectively;
- Gullies must not be spaced more than 40m apart, irrespective of the areas drained, except at summits where the first gully should not be more than 40m from the high point;
- Double gullies must always be provided at sag points and low points and each must have its individual connection to the main sewer or highway drain.

In footpaths, footways and cycleways separated from carriageways, you must provide gullies or channels connected to the highway drainage system where surface water would otherwise discharge onto adjacent property or cause flooding of footpaths, footways or carriageways.

You should site gullies upstream of the tangent point at road junctions so that surface water in the channel does not flow across the junction. You should take care to avoid ponding near the mid-point of radius kerbs. Where the road is super-elevated, you should site a gully just before the point where the adverse camber is removed to prevent water in the upstream channel flowing across the carriageway.

You should take care to avoid ponding in the transition length, when the longitudinal gradient is flat or where there are traffic islands, central reserves or traffic-calming measures. You must not site gullies within pedestrian crossing points. Where possible, locate them directly upstream of the crossing point.

You should not site gullies where traffic would be prevented from passing while they are being emptied, for example within a carriageway width restriction.

You will need to provide us with a contour plan to show that gullies are located in the correct position as part of your design submission for works under Section 38 or Section 278 agreements.

#### **5.2.18 Providing sub-soil drainage**

You should generally construct a system of sub-soil drainage to a suitable outfall all to our satisfaction unless otherwise agreed where:

- the winter height of the water table is within 600mm of formation level; or
- the sub-soil is unstable because of being waterlogged; or
- there is a likelihood of water running from or out of adjacent ground; or
- springs, land drains or watercourses are present; or
- the finished road is below existing ground level, regardless of the water table; or
- the sub-grade is likely to be altered due to groundwater.

#### **5.2.19 Backfilling trenches**

You must backfill all drainage, utility and other trenches in the highway for industrial and commercial premises up to formation level with GSB type1 granular sub-base material.

Backfill on residential sites should be a granular material to the approval of the highway authority (acceptable material will typically include GSB type 1 or material graded to 6F1).

[End]

# Utility Services

## Part 5.3

### 5.3.1 Making Provision for Utility Services

There are no statutory obligations governing the position or depth at which apparatus should be laid within the highway. On new development sites where utility apparatus is to be installed, the NJUG guidelines for the positioning and colour coding of underground apparatus should be followed. Any deviation from these guidelines should only be conducted with the agreement of the prospective asset owners and the County Council. With the exception of essential road crossings, mains utility services should not be located in the carriageway unless the carriageway is a shared surface designed with an area to accommodate utility apparatus (see guidance on shared surfaces).

It is essential that only planting with a shallow root system (usually grass) is located within service strips. Where a service strip is to accommodate existing vegetation it must be wide enough to avoid damage to existing root systems. Banks or mounds should not encroach onto service strips and levels should not be altered over existing apparatus without prior consent from the respective undertakers affected.

Mains services must be provided in a manner whereby repair and maintenance can be carried out without obstructing passage. Service strips must be appropriately delineated and developers must make it clear to purchasers that the service strip is not conveyed to the property. However, the maintenance responsibility for service strip planting may be assigned to individual properties in their deeds.

Where the provision for services is not well defined, the street layout should be agreed with the County Council at pre-planning application stage to avoid unnecessary delay to the planning process and potential redesign.

### 5.3.2 NJUG guidelines on the positioning of underground utilities

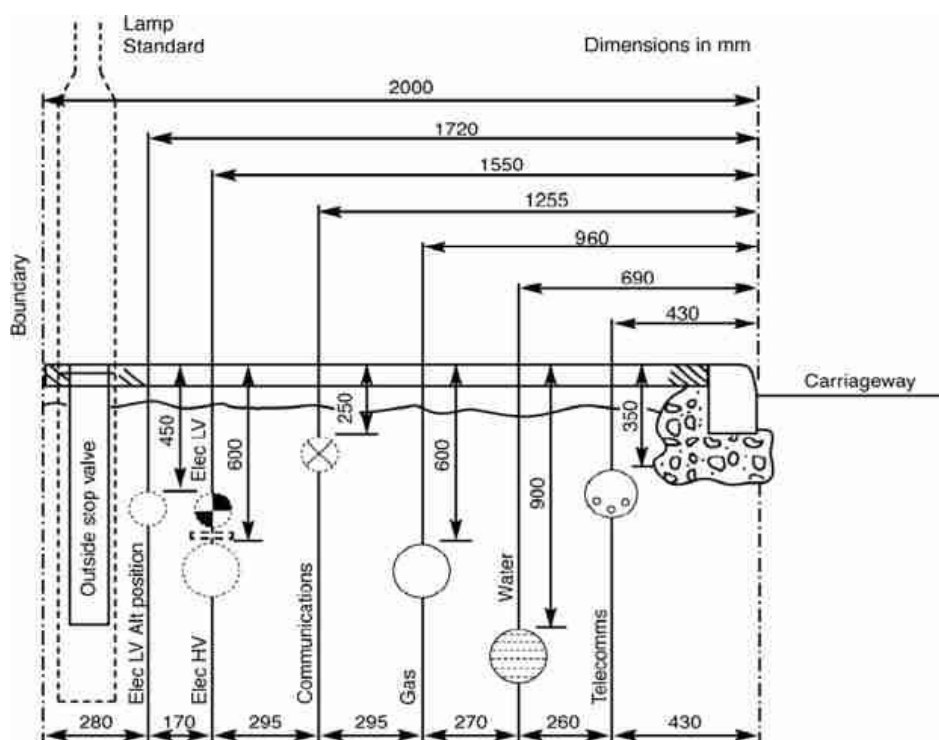

### **5.3.3 Backfilling trenches**

You must backfill all drainage, utility and other trenches in the highway for industrial and commercial premises up to formation level with GSB type1 granular sub-base material.

Backfill on residential sites should be a granular material to the approval of the County Council (acceptable material will typically include GSB type 1 or material graded to 6F1).

[End]

# Structures

## Part 5.4

### Specification

5.4.1 All highway works must normally be in accordance with the 'Specification for Highway Works' published by Her Majesty's Stationery Office as Volume 1 of the Manual of Contract Documents for Highway Works (MCHW) and comply with the 'Notes for Guidance on the Specification for Highway Works' published as Volume 2, as well as our specification and standard drawings. Where these vary from the 'Specification for Highway Works' our documents should prevail. If your proposals are not covered by the standard drawings, you will need to submit scheme-specific drawings to us for approval.

### Definition

5.4.2 Highway related structures will normally include bridges, tunnels, retaining walls, corrugated-steel buried structures, reinforced soil and anchored earth structures, reinforced clay brickwork retaining walls of pocket-type and grouted-cavity construction, crib wall retaining walls of concrete or timber construction, environmental barriers (including noise barriers and fencing), and all drains, piped and box culverts, sewers and drainage structures, other than bridges, that have a diameter or clear span of more than 900mm.

5.4.3 A highway related structure is either any structure built in, under, or over, the highway; or any retaining wall or structure which supports the highway and where the structure, or any retaining wall is built within 3.65m of the highway boundary where the retained height above the adjacent highway is 1.4m, or more, S167 Highways Act 1980.

Note: The definition of 'highway' used above includes the carriageway, footway and all verges.

### Design

5.4.4 All highway related structures, whether we are to adopt them or not, must be designed and constructed in accordance with the current relevant codes of practice and technical memoranda. The design will be subject to the technical-approval procedure set out in the Department for Transport Design Manual for Roads and Bridges 'CG 300 Technical approval of highway structures' except that the Technical Approval Authority will be us.

5.4.5 You must employ a chartered civil or structural engineer with experience in highway structures and approved by us to carry out the design and oversee construction.

5.4.6 Before construction begins, you must provide a programme of supervision for our approval. The programme must give details of the level and amount of supervision that will be provided so we are confident that the structure will be built in accordance with the design and specification. The programme must also contain proposals for materials testing.

5.4.7 At regular intervals, we will audit the supervision of a scheme to make sure that you are meeting the agreed programme of supervision. However, it is the developer's responsibility to keep us informed of the proposed programme. Before adoption, you must give us copies of approved design calculations (if not already received), inspection certificates, material-testing certificates, digital photographs (\*.JPG or\*.BMP format), as-built drawings preferably in an electronic form, (for example PDF file), maintenance manuals and a Construction Compliance Certificate in accordance



with the Design Manual for Roads and Bridges. This information should be submitted in advance of a request for a final certificate of completion to the County Council (full adoption certificate). Failure to accord to the approved design and insufficient collation of the required evidence will jeopardise the ability of the County Council to adopt structures.

5.4.8 You will have to pay the additional design checking and inspection fees for any highway structure. This is charged at 'actual' rate and we will give you an indication of the likely fee at our earliest opportunity. You must pay a commuted sum for future maintenance of any highway structure to be adopted.

[End]

# New Roads, the Advance Payments Code, and Section 38

## 6.1 The Advance Payments Code (“the Code”) Section 219 to 225 Highways Act 1980 (“the Act”)

In accordance with Section 220 of the Act, all new buildings that would face a private street are liable for the cost of the private street works unless specifically exempt by way of Section 219 or a Section 38 agreement has been previously entered into. Otherwise we are required to serve notice on the person who submitted plans for building regulations approval seeking payment of our estimated cost of the streets works.

**WARNING** - If works start on any building without paying the sum specified in the notice, the landowner will be committing an offence, and we may take them to court.

Once payment has been made, this will be returned if a Section 38 agreement has been entered into or the works are finished to a standard that we judge will provide a durable road construction and being satisfied that there is no prospect of the road requiring further private street works in the future. Note that completing this process does not mean that the road will be of an adoptable standard, in which case, it will remain private and we will not be maintain it at public expense. A fee will apply similar to a Section 38 agreement if you wish the detailed design of the road and works construction to be approved by us to allow future adoption.

We and most builders prefer the Section 38 agreement route to highway adoption as it offers more certainty with respect future road adoption and the return of the security sum.

## 6.2 Private Roads

If you clearly indicate that you would not wish for a street to be adopted, you must submit a plan to us under Section 31(6) of the Act identifying the extent of the private street, enter into a legal agreement under Section 106 Town and Country Planning Act to indemnify us against future petitioning by residents to adopt their street under Section 37 of the Act and to secure future private maintenance arrangements for the street. We may then be in a position to exempt the development from the Code once completed if we deem this to be appropriate.

## 6.3 Section 38 agreements

Section 38 of the Act is the mechanism used to ensure most roads constructed as part of development become highways maintainable at public expense (adopted) by way of entering into a Section 38 agreement. Parties to the agreement must include all landowners as well as the developer if different.

## 6.4 Approvals

Before carrying out any technical approval checks, we will require payment of our costs for any checking of the design. This will usually be circa 50% of the total fee. The balance of the

administration and inspection fee will be payable on signing of the agreement. Additional fees may apply.

The following information is required before the Section 38 check can be processed:

### **6.5 Layout:**

- Plans indicating the areas of proposed highway offered for adoption;
- Plans indicating the position of all carriageways, footways, footpaths, cycle ways, verges service strips, visibility splays, traffic calming features, surface water drainage including gully positions, position of dwellings, gradients of driveways, garaging and/or parking spaces with vehicular crossings, traffic signs, road markings, structures, bus stops, and bus stop infrastructure;
- For layouts not conforming to normal HA standards, a drawing and schedule indicating different materials proposed together with appropriate areas for use in the calculation of commuted sums;
- Drawings in pdf format will be printed and distributed as required;
- Quality Audit if required.

### **6.6 Vertical Alignment:**

- Longitudinal sections of the carriageway showing existing and proposed levels for the centre line, channel, gradients and vertical curves with the appropriate horizontal road layout drawn below this section;
- Longitudinal sections must also indicate surface and foul water sewer profiles including the position of manholes, gradients, pipe sizes etc.

### **6.7 Standard Details:**

- Typical cross sections showing carriageway, footway and verge construction including details of kerbs and edgings (as per standard drawings)
- Typical construction details of footways, footpaths, cycle ways, vehicular accesses and pedestrian crossing points kerbs, manholes and pipe bedding (as per standard drawings);

### **6.8 Ground Conditions:**

- A geotechnical report, including CBR test results at formation.

### **6.9 Drainage:**

- Details of existing and proposed surface and foul water drainage, including a highway gully layout;
- Calculations of surface water run-off, 'micro drainage' etc;
- A manhole schedule;
- Details of deeds of easements and discharge consents.

### **6.10 Landscaping:**

- Details of planting and additional maintenance proposals.

### **6.11 Other Features:**

- Any specialist information regarding bridges, culverts, headwalls and retaining walls supplied on separate drawings.

### **6.12 Street Lighting:**

- Street lighting layout and specification in accordance with BS5489, together with details on any impact on the existing lighting system.

### 6.13 S38 Plan

We will only issue technical approval after all additional information and requested amendments have been received.

The design will require accompanying by a plan to be inserted in the Section 38 agreement coloured up as follows:

- Site boundary - red
- carriageway – grey
- footways, footpaths, cycle ways and other hard-surfaced areas – yellow
- shared-surface roads – brown
- traffic-calming features – brown
- verges – green
- highway drainage – blue
- additional highway structures – pink
- special surfacing – purple
- Street lighting - red

### 6.14 Section 38 plan example



We will prepare all documentation for the Section 38 agreement. Details to be provided at this time include:

- the name and address of the landowner;
- your name and address as the developer;
- the name and address of any bondsman or confirmation of cash deposit;
- the name and address of the solicitor;
- proof of ownership of the land; and
- proof of an intention to enter into a Section 104 agreement and any deeds of easements.

Our solicitor will seek an undertaking from your solicitor confirming that our legal fees will be met.

### **6.15 Pre-commencement**

You must not begin construction unless and until:

- we have given you technical approval;
- the Section 38 agreement has been completed and signed and an appropriate surety is set in place;
- you have notified the Health and Safety Executive that you are client for the works for the purposes of the Construction (Design and Management) Regulations;
- all necessary fees have been paid to us;
- you have complied with the New Road and Street Works Act minimum notification periods;
- the contractor (including any subcontractor) has been approved;
- You have demonstrated that £5m public liability insurance is in place including indemnity to principal;
- a pre-start meeting has been held.

### **6.16 Site inspection**

You are responsible for the day-to-day supervision of the road works construction. We will only inspect the works to check that they are being constructed in accordance with the approved drawings and our requirements. You must give our representative access to the works in progress at all times. If problems arise, we will be happy to discuss possible solutions with you, but it will still be your responsibility to instruct your contractor and make sure that the works are satisfactorily completed in accordance with our requirements.

### **6.17 Substantial completion**

We will issue the first certificate of completion once:

- you have substantially completed the road works to our satisfaction;
- you have completed all street lighting to our satisfaction;
- any new planted landscaping areas, grassed areas, trees, shrubs and so on that we are to adopt have been fully planted and established;
- the works (including any existing and new planted landscaping areas and so on) have been jointly inspected (that is by us, you and your contractor) and no significant defects have been identified, or where they have, you have agreed to remedy them to our satisfaction; and
- where required, any stage 3 safety audit has been completed and all changes that we require have been made satisfactorily;
- You must provide us with 'as built' drawings, preferably in an electronic form.

When we issue a first certificate, the amount of bond excluding the commuted sums element can be reduced, usually to 40% of the original amount. The exception to this is where you are paying us a commuted sum in which case the bond cannot be reduced to a value less than the commuted sums that we have calculated.

You will then be responsible for maintaining the roadworks for a minimum period, usually twelve months. This allows any defects in the works to become apparent after they are brought into use.

### **6.17 Final Completion**

We will issue a second certificate of completion when the following actions have taken place:

- You must contact us at the end of the maintenance period to arrange a further joint inspection of the road works (including any landscape planting, trees, grassed areas and so on). We will issue you with a list of any outstanding remedial works we require you to do, which you must then complete to our satisfaction;
- You must have maintained the road works to our satisfaction during the maintenance period;
- You must provide us with a copy of the provisional certificate of adoption for the drainage and sewers, as issued by the relevant water company;
- You must pay us any commuted sums and outstanding charges that are required;
- You must provide us with the health and safety file in an electronic form produced in line with the Construction (Design and Management) Regulations.

After all of the above has been done to our satisfaction, we will:

- issue a second certificate of final completion;
- inform you that the bond can be cancelled; and
- adopt all areas dedicated within the Section 38 agreement as highway to be maintained at public expense.

[End]



# Off-site Highway Works, Accesses, Junctions, and Section 184 and 278

## **7.1 Vehicular crossing - Section 184 approval**

To get your vehicle from the road and onto your drive you will need a properly constructed 'vehicular crossing', also known as a 'dropped kerb'. This is to prevent damage to the pavement and/or verge and to protect underground pipes and cables. You will require our approval and you may also need to get planning permission from your local district council, for instance if you live on a classified road.

You may employ a contractor of your choice to carry out these works, subject to them meeting certain requirements. Your contractor will need to apply to us for a permit to alter the highway outside your property and we will inspect the work to ensure that it meets our specification. A fee will apply.

## **7.2 Section 278 agreements, Highways Act 1980 (“the Act”)**

We use this section of the Act to allow you, the developer, to employ a contractor and for that contractor to work on the existing public highway in the same way as if we, the County Council, were carrying out the works instead usually to facilitate development. You are normally responsible for all aspects of the works on the public highway, from their design, through supervising construction and ensuring that the works are fully completed to our satisfaction.

It should be emphasised that works which directly affect the Strategic Road Network (SRN) will need to be considered separately by Highways England and are as such not bound by the contents of this document. The SRN both borders and runs through the County and certain locations interfaces directly with the Local Road Network.

For the avoidance of doubt all works which affect the SRN shall be designed fully in accordance with the Design Manual for Roads and Bridges (DMRB) and specified in accordance with the Manual of Contract Document for Highway Works (MCHW). Highways England should be contacted at an early stage.

## **7.3 Approvals**

Before carrying out any technical approval checks, we will require payment of our costs for any checking of the design. This will usually be circa 50% of the likely total fee. The balance of the administration and inspection fee will be payable prior to the signing of the agreement. Additional fees may apply.

The following information is required before the Section 278 check can be processed:

## **7.4 General**

- 1:1250 plan showing scheme extents, and existing road network. (An alternative scale may be used to suit nature/size of scheme);

## **7.5 Detailed design layouts 1:500 Plans showing:**

- Site clearance details;

- Drainage layout: Pipe runs, manhole and gully positions. Pipes intended for adoption should be highlighted;
- Earthwork details;
- Carriageway and footway construction details indicating areas of different pavement types areas of overlay, reconstruction, planing etc.;
- Kerbing and edging details;
- Traffic sign positions and road markings. Each sign should have an accompanying schedule giving post sizes, mounting heights illumination details, foundation details etc.;
- Landscaping proposals;
- Road lighting positions;
- Fencing proposals showing highway boundary positions and visibility splays;
- Safety fence layout;
- Structures position and orientation;
- Electrical works i.e. trenches and cabling;
- Bus stop locations and bus stop infrastructure;

## **7.6 Vertical design**

- Longitudinal sections showing centreline and channels in relation to existing ground levels;
- Proposed gradients and k values for sag and crest of curves, horizontal schematic showing curve radii, transitions;
- Cross sections showing proposed levels and profile in relation to existing levels and proposed/existing;
- Boundaries.

## **7.7 Junction design**

### **7.7.1 Roundabouts:**

- Provide 1:200 or 1:500 plan showing proposed spot levels, contours and crown lines;
- Provide design checklist to ensure geometric compliance with DMRB – CD 116 Geometric Design of Roundabouts;
- Provide existing, generated & forecast turning flows for the morning and evening peak periods;
- Provide traffic reserve capacity calculations for the AM & PM peak periods using the latest version of ARCADY;
- Demonstrate deflection;
- Show visibility lines;
- Provide segregation for cyclists and pedestrians as required.

### **7.7.2 Priority junctions:**

- Provide 1:200 or 1:500 plan showing proposed spot levels, contours and crown lines;
- Provide design checklist to ensure geometric compliance with DMRB – CD 123 Geometric design of at-grade priority and signal-controlled junctions;
- Provide existing, generated & forecast turning flows for the morning and evening peak periods;
- Provide traffic reserve capacity calculations for the AM & PM peak periods using the latest version of PICADY; Justification for the chosen specific layout;
- Provide suitable routes for pedestrians and cyclists as required



### **7.7.3 Traffic signal junctions:**

- Provide a 1:500 or 1:200 plan on a topographical base showing signal heads, pole position, ducting etc.;
- Provide existing, generated and forecast turning flows for the morning and evening peak periods;
- Provide appropriate traffic reserve capacity calculations for AM and PM peak periods using LINSIG;
- Ensure that design complies fully with DMRB – CD 123 Geometric design of at-grade priority and signal-controlled junctions;

### **7.7.4 Pedestrian crossing facility**

- Provide a 1:500 or 1:200 plan on a topographical base, showing signal heads, pole position, ducting etc.;
- Ensure that design complies with the following standards/advisory notes (as appropriate):
  - Traffic Advisory Leaflet – 1/02 The Installation of Puffin Pedestrian Crossings;
  - Traffic Advisory Leaflet – 04/98 Toucan Crossing Development;
  - Traffic Advisory Leaflet – 10/93 ‘Toucan’ An unsegregated Crossing for Pedestrians and Cyclists;
  - Statutory Instruments – 1997 No.2400- Road Traffic – The Zebra, Pelican and Puffin Pedestrian Crossings Regulations & General Directions 1997;
  - Design Manual for Roads and Bridges (DMRB) – TD 101 Traffic Signalling Systems
  - DMRB (Vol 8) – TA 15/07 – Pedestrian Facilities at Traffic Signal Installations;
  - DMRB (Vol 6) – TA 86/03 – Layout at Large Signal Controlled Junctions;
  - DMRB – CD 143 Designing for Walking, Cycling and Horse-Riding;
  - DfT Guidance on the use of Tactile Paving Surfaces

### **7.8 Statutory Undertakers (for example gas, water, cable TV)**

Plans showing existing apparatus along with any diversion/protection proposals.

### **7.9 Structures**

Design must comply with agreed Approval in Principle (AIP). All design/check certificates in accordance with DMRB CG 300 Technical Approval of Highway Structures shall be supplied for us to endorse.

The following drawings are required:

General arrangement:

- Detail design – details should include: dimensions, levels, materials and finishes, drainage and service ducts, parapet details, earthwork details, foundation details;
- Reinforcement details showing – cover to steel and reinforcement details in accordance with BS 8666:2005 incorporating amendment No.1.

Geotechnical Information:

- Initial ground investigation proposals;
- Desk study information including preliminary deep borehole work;

- Ground investigation including detailed proposals with borehole locations, schedules, long sections and laboratory testing philosophy;
- Factual report;
- Interpretative report including calculations;
- Earthworks design including drawings and specification;
- Structural foundation design

**'Buildability':**

- Does the design allow for the contractor's input?
- Provide evidence that construction issues have been addressed in the design, for example 'Beany' blocks constructed to default radii, manholes positioned out of the carriageway.

**Traffic management:**

- Are road closures required?
- Provide information for both local and heavy diversion routes (where appropriate);
- Give evidence on the provisions made for local transport services during the construction phase.

**Drainage design:**

- Drainage design calculations/output;
- Gully spacing design output;
- Provide information on the depths of cover of lines;
- Provide invert and chamber sizing of access chamber;
- Provide discharge calculation at the outfalls;
- Provide details of retention storage;
- Provide calculations and information on mechanical elements e.g. pumps and throttles;
- Provide information on petrol interceptors.

**Landscaping:**

- Provide information on planting strategy;
- Provide drawing of planting areas;
- Provide planting specifications;
- Give information on the preparation works and also soil types to be used;
- Provide listing of all species of plants and density;
- Provide maintenance regime.

**Construction Design and Management Regulations:**

- Provide all risk assessment and a copy of the pre-tender health and safety plan;
- Provide a copy of F10.

**Other Supporting Information Required:**

- Traffic flows;
- Carriageway construction design calculation;
- CCTV videos of any existing drainage used as outfall/connection;
- Sign schedules;
- Autotrak plots for HGV manoeuvres at appropriate locations;
- Stage 2 safety audit problems, recommendations and designer's responses where appropriate;
- Standard drawings should be used except where no appropriate detail covers the proposal.

## **7.10 Technical Approval**

We will only issue technical approval after all additional information and requested amendments have been received.

We will prepare all documentation for the Section 278 agreement. Details to be provided at this time include:

- the name and address of the landowner (if a highway dedication is required);
- your name and address as the developer;
- the name and address of any bondsman or confirmation of cash deposit;
- the name and address of the solicitor; and
- proof of an intention to enter into a Section 104 agreement and any deeds of easements (if required).

Our solicitor will seek an undertaking from your solicitor confirming that our legal fees will be met.

### **7.11 Pre-commencement**

You must not begin construction unless and until:

- we have given you technical approval;
- the Section 278 agreement has been completed and signed and an appropriate surety is set in place;
- you have notified the Health and Safety Executive that you are client for the works for the purposes of the Construction (Design and Management) Regulations;
- all necessary fees have been paid to us;
- you have complied with the New Road and Street Works Act minimum notification periods;
- the contractor (including any subcontractor) has been approved;
- You have demonstrated that £5m public liability insurance is in place including indemnity to principal; and
- a pre-start meeting has been held.

### **7.12 Site inspection**

You are responsible for the day-to-day supervision of the road works construction. We will only inspect the works to check that they are being constructed in accordance with the approved drawings and our requirements. You must give our representative access to the works in progress at all times. If problems arise, we will be happy to discuss possible solutions with you, but it will still be your responsibility to instruct your contractor and make sure that the works are satisfactorily completed in accordance with our requirements.

### **7.13 Substantial completion**

We will issue the first certificate of completion once:

- you have substantially completed the road works to our satisfaction;
- you have completed all street lighting to our satisfaction;
- any new planted landscaping areas, grassed areas, trees, shrubs and so on that we are to maintain have been fully planted and established;
- the works (including any existing and new planted landscaping areas and so on) have been jointly inspected (that is by us, you and your contractor) and no significant defects have been identified, or where they have, you have agreed to remedy them to our satisfaction; and

- a stage 3 safety audit has been completed and all changes that we require have been made satisfactorily.

When we issue a first certificate, the amount of bond excluding the commuted sums element can be reduced, usually to 40% of the original amount. The exception to this is where you are paying us a commuted sum in which case the bond cannot be reduced to a value less than the commuted sums that we have calculated.

You will then be responsible for maintaining the roadworks for a minimum period, usually twelve months (soft landscaping is usually subject to 3 year maintenance period). This allows any defects in the works to become apparent after they are brought into use.

#### **7.14 Final Completion**

We will issue a second certificate of completion when the following actions have taken place:

- You must contact us at the end of the maintenance period to arrange a further joint inspection of the road works (including any landscape planting, trees, grassed areas and so on). We will issue you with a list of any outstanding remedial works we require you to do, which you must then complete to our satisfaction;
- You must have maintained the road works to our satisfaction during the maintenance period;
- You must provide us with a copy of the provisional certificate of adoption for any drainage and sewers, as issued by the relevant water company;
- You must pay us any commuted sums and outstanding charges that are required;
- You must provide us with 'as built' drawings, preferably electronically or on CD;
- You must provide us with the health and safety file, electronically or on CD, produced in line with the Construction (Design and Management) Regulations 2015 (CDM).

After all of the above has been done to our satisfaction, we will:

- issue a second certificate of final completion;
- inform you that the bond can be cancelled; and
- adopt all areas to be dedicated within the Section 278 agreement as highway to be maintained at public expense.

[End]



# Commuted Sums

## Part 8.0

### Introduction

8.1 In the context of this guidance commuted sums are financial contributions made by third parties to the County Council as compensation for taking on the future maintenance responsibility for newly created highways or highway improvements. They are typically secured through legal agreements made with developers and landowners under Sections 38 and/or 278 of the Highways Act 1980 (“the Act”).

8.2 The calculation of the commuted sum is the subject of individual agreements. This note sets out our common approach as to how the commuted sum is calculated. This Authority has adopted the Adept (formerly County Surveyors Society) guidance document ‘Commuted Sums for Maintaining Infrastructure Assets’.

### Legal Background

#### New roads adopted under Section 38

8.3 Section 38 of the Act is a power allowing highway authorities to adopt newly constructed roads by agreement with landowners and developers. Section 38(6) states as follows:

*“An agreement under this section may contain such provisions as to the dedication as a highway of any road or way to which the agreement relates, the bearing of the expenses of the construction, maintenance or improvement of any highway, road, bridge or viaduct to which the agreement relates and other relevant matters as the authority making the agreement think fit”.*

8.4 The Court of Appeal has emphasised the wide and unqualified nature of the Section 38(6) powers. There are no limitations as to how the commuted sum should be calculated (Redrow Homes Ltd v Knowsley MBC [2015]) and this need not be limited to “extra over” costs.

#### Existing roads improved under Section 278

8.5 Section 278 of the Act is a power allowing highway authorities to secure improvements to existing roads by agreement with landowners and developers.

8.6 Section 278(3) states as follows:

*“The agreement may also provide for the making to the highway authority of payments in respect of the maintenance of the works to which the agreement relates and may contain such incidental and consequential provisions as appear to the highway authority to be necessary or expedient for the purposes of the agreement”.*

8.7 Section 278 is therefore drafted in the same wide and unqualified terms as Section 38 of the Act.

### Application

8.8 The need for paying commuted sums can be divided into four broad categories.

- The cost of maintaining areas and construction which, under our normal design guidance are not required for the safe and satisfactory functioning of the highway. Examples are additional

areas of carriageway, such as a 'square' surrounding a turning head, hard landscaping, grass verges, and so on.

- The cost of maintaining some features of the adoptable works which can be considered as extra over. Examples include highway structures, public transport infrastructure, landscaping, trees, shrubs and so on, additional or non-usual street furniture and noise fencing. These costs represent an increase in our future maintenance liability which will be more than the anticipated normal funding generated by the development.
- The additional cost of maintaining permitted alternative materials and features which are extra over. Examples include surfacing materials and street lighting equipment. These additional costs are in excess of what we would have incurred if the materials and features used had been to the standard specification.
- Sustainable drainage systems (SUDS), for example, flow-attenuation devices, swales and storage areas.

Note: Where you are proposing SUDS, you must hold discussions with all relevant parties at an early stage (and certainly before any planning application) to agree ownership and responsibility for the facility.

8.9 This is not an exhaustive, detailed list. It is only intended to illustrate broad principles. Cases where commuted sums will normally be required are set out in other parts of this document. You should always discuss with us where commuted sums might be required at the earliest possible opportunity and certainly before any planning application.

### **Calculating commuted sums**

8.10 We work out the cost your maintenance obligation using this formula:

$$\text{Committed sum} = \sum Mp / (1 + D/100)^T$$

Mp = Estimated periodic maintenance cost

D = Discount rate (effective annual interest rate) (%)

T = Time period before expenditure will be incurred (years)

### **Maintenance unit costs (Mp)**

8.11 Maintenance unit costs are based on contract rates current at the time of calculation and the frequency of treatment or intervals of replacement, based on planned frequencies or historic information. A sum of 10% of the works costs will be added to cover our design and supervision costs.

### **Discount rate (D)**

8.12 The discount rate (effective annual interest rate) is worked out as follows:

$$\begin{aligned} D &= (1.045/1.0225) - 1 \\ &= 2.2\% \end{aligned}$$

Where 1.045 is the interest rate (4.5% based on long-term neutral base rate) and 1.0225 is the inflation rate (2.25% based on RPI-X that is RPI excluding mortgage payments)

### **Time period (T)**

8.13 There is a case for using a time period equal to the expected life of the development in the case of development roads. However, for the time being, a time period of 60 years will be used to calculate the commuted sums, with the exception of highway structures when a 120-year period will apply, in accordance with the standard design life requirement.

## Agreement, Bond, & Timing

8.14 You will be required by the relevant agreement with us to pay us a commuted sum. Any commuted sums you must pay will be included in the bond required under the Section 38 or Section 278 agreement. The commuted sum will be payable before we issue the final certificate.

8.15 For Section 278 works we will not normally apply commuted sums for the existing area of carriageway unless replaced with a non-standard material (in that case the commuted sum would be the difference between the commuted sum for the standard and non-standard material). A full commuted sum would be required for any additional carriageway created (e.g. a right turn lane), or any new feature created (e.g. refuge/splitter island, additional lighting, bollards etc). This is because the additional carriageway and features created above those already existing are only required to provide the access for the new development, and therefore it is reasonable to require a commuted sum to maintain them in the future.

### *Commuted sum example*

*Annual maintenance cost for example £100*

*Replacement cost for example £500*

*Design life for example 20 years*

*Discount rate 2.2% (0.022)*

*Calculate for each year up to 60 years including replacement cost as required:*

$$\text{Year 1} - £100 \div (0.022\% + 1)^1 = £97.85$$

$$\text{Year 2} - £100 \div (0.022\% + 1)^2 = £95.74$$

$$\text{Year 3} - £100 \div (0.022\% + 1)^3 = £93.72 \text{ and so on up to year 20}$$

$$\text{Year 20} - £500 \div (0.022\% + 1)^{20} = £323.56$$

$$\text{Year 21} - £100 \div (0.022\% + 1)^{21} = 63.32 \text{ and so on up to year 40}$$

$$\text{Year 40} - £500 \div (0.022\% + 1)^{40} = £209.38$$

$$\text{Year 41} - £100 \div (0.022\% + 1)^{41} = £40.97 \text{ and so on up to year 60}$$

$$\text{Year 60} - £500 \div (0.022\% + 1)^{60} = £135.49$$

*Each value for each year is then summed.*

[End]



## Appendix A

### Changes log

<b>Published Date</b>	<b>Chapter / Paragraph(s) affected</b>	<b>Description of change</b>
7/8/20	Part 1.0 now Part 1.1 & 1.2	Intro & Policy split into separate chapters, paragraphs numbers added
6/8/20	1.1.3	Document status and changes log added, Chapter 1.0 paragraphs renumbered, contact details added.
6/8/20	1.1.6	Aims added
5/8/20	1.1.7	Highways England requirements added
12/08/20	1.2.10	Possibility of Technical Note added to deal with minor changes to large development
6/8/20	1.2.5	NPPF version updated
6/8/20	2.2	Building for Life reference and NPPF version updated
6/8/20	2.5	Clarified
11/8/20	2.8	Walking distance to stops updated
11/8/20	T3.1.1	Bus stop locations and infrastructure updated, cycling facilities added
11/8/20	T3.2.1	Bus stop locations and infrastructure updated
19/8/20	3.2.1	Purpose of table added
12/8/20	T3.1.1	Access way definition updated
12/8/20	T3.1.1	Main Street 20mph vis splay added
12/8/20	T3.1.1	Cycle provision to comply with LTN1/20
12/8/20	T3.1.1	Clarification on forward splays added
12/8/20	T3.2.1	Vis 'X' distances added
19/8/20	T3.1.1	Street function updated
19/8/20	3.1.1	Purpose of table added
11/8/20	3.3	SSD calculation example added
5/8/20	3.3	DMRB visibility splay formula deceleration constant corrected
12/8/20	3.3	Wet weather conversion added, DMRB references removed, splays to be in the control of developer added.
12/8/20	3.3.2	Setback for vegetation wording amended
6/8/20	3.8	Paragraph numbers added to bin storage



11/8/20	4.1.1	Parking requirement for HMOs, retirement homes, sheltered accommodation etc. added and option to survey
12/8/20	4.1.1	Garage door dimensions amended
12/8/20	4.1.13	Cables not to obstruct footways etc. added
6/8/20	4.2.6	Table update considering LTN 1/20
6/8/20	4.1.8	Narrative updated considering LTN 1/20
6/8/20	5.1.13	Equilibrium CBR clarified
6/8/20	5.1.17	Binder course thickness increased from 50mm to 60mm
6/8/20	5.1.45 & 5.1.46	Adoption of trees and verges clarified
12/8/20	5.1.40	Clarity added to street lighting requirements
11/08/20	6.5	Bus stop details added
11/08/20	7.5	Bus stop details added
6/8/20	Throughout	Table references added
11/8/20	8.0	Commuted sum example added
8/9/20	1.2, 3.2, 4.2	Use class references removed
22/9/20	1.8	Use of DMRB added, paragraphs renumbered
30/9/20	1.1.7	Added to encourage walking and cycling
22/10/20	5.2.4 & T5.2.1	Infiltration rates added & gully spaces corrected
2/11/20	5.2	SUDS/Soakaways advice revised
17/12/20	T3.1.1	Minimum carriageway width for cyclists at refuges added
21/12/20	5.1.18	Typo removed text clarified
8/1/21	T1.2	Drive-thru restaurants added
18/1/21	3.1	Turning heads updated

[End]

**Table B.6 Infiltration assessment checklist**

Requirements	
Site ID	
Asset ID	
Infiltration component location	
Infiltration component type	

Infiltration capacity	Details	Acceptable submission?	Further requirements
Confirm that infiltration test results have been provided, along with trial pit records with soil/rock descriptions of the materials in which the test has been completed in accordance with BS EN ISO 14688-1:2002+A1:2013 or BS EN ISO 14689-1:2003			
Confirm that the infiltration tests have been undertaken at the location, depth and with a head of water that replicates the proposed design			
Confirm that infiltration tests state which stratum the results are appropriate to and any limitations in the test. For example, has the infiltration rate been estimated by assuming water only infiltrates into one particular stratum such as a discrete layer of limestone?			
Confirm that the infiltration tests follow BRE (1991) or Bettess (1996) as far as is relevant to the design. If not, state what variations have been made to the test and why			
Confirm that the head of water in the infiltration test falls to less than 25% of the initial head of water. (Note: if this does not occur the results should not be extrapolated – the results should state “Infiltration test cannot be determined.”)			
Confirm that account has been taken of the soil descriptions and an assessment of the likely impact of water on the soil and long-term infiltration rate has been included (eg high initial infiltration rates in dry mudstone may not be representative of long-term values when soaking water has caused weathering)			
Confirm what measures are necessary to prevent construction activities (especially compaction) changing the infiltration characteristics			
Confirm that the test infiltration capacity is likely to be representative of the wider ground mass (eg the test has not been undertaken in a limited extent of sand within a mass of clay)			
Groundwater levels			
Confirm that evidence has been provided of groundwater levels and seasonal variations (eg via relevant groundwater records or on-site monitoring in wells)			

Infiltration capacity	Details	Acceptable submission?	Further requirements
Confirm that the maximum likely groundwater levels are >1 m below the base of the infiltration device			
<b>Ground stability</b>			
Confirm that it has been demonstrated that infiltration will not cause significant risk of instability (eg retaining walls, slopes, solution features or loosely consolidated fill) or movement that could adversely affect any nearby buildings or other structures. Where infiltration is proposed closer than 5 m to the foundations of buildings or structures that this assessment should be approved by a suitably qualified professional such as a registered ground engineering adviser. The BGS Infiltration SuDS Map is a useful source of information. Some local authorities have solifluction maps			
Confirm that an assessment has been taken of the potential for subsidence due to infiltration			
<b>Ground contamination</b>			
Confirm that an assessment of the potential for deterioration in groundwater quality due to infiltration, such as due to mobilisation of contamination, has been undertaken. Note: this assessment should be undertaken by a qualified geo-environmental engineer or similarly qualified person, and may require a site investigation with contamination testing. The BGS Infiltration SuDS Map can provide useful preliminary information			
Confirm that a suitable treatment train has been provided before the runoff reaches the soil (to reduce risks of groundwater contamination to an acceptable level) – see National SuDS Standards and this manual			
<b>Flood risk</b>			
Confirm that an assessment has been undertaken of the potential effect of infiltration on groundwater levels local to any infiltration component and the potential wider impact of multiple infiltration components within the site, with respect to groundwater flood risk			
Confirm that an assessment has been undertaken of the risk of springs developing in layered geology/steep topography due to the proposed infiltration			
Confirm that details of overflows or additional discharge points if total infiltration cannot be relied on for all return period events have been provided			
<b>Combined sewer risk</b>			
Confirm that an assessment has been undertaken of the risk of groundwater leakage into any local combined sewers			